

## 高輝度照明用LED

### WLED™

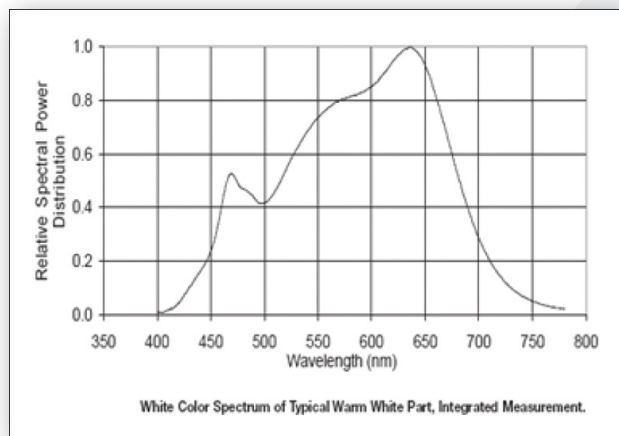

コンパクトなパッケージで、  
高輝度のスポット照明

## High power LED Illuminator

### 特長

- ☆コンパクトで、軽量
- ☆輝度にかかわらず、色温度を一定に保持
- ☆低電力
- ☆かさばるファイバーバンドル不要
- ☆長寿命

微細加工および顕微鏡用一般照明として最適の、同軸照明用白色LEDユニットです。タングステンハロゲン球に固有の発熱、かさばるファイバーバンドル、球の定期的換から開放されます。

LED光源の期待寿命は、タングステンハロゲン球の50倍と長寿命で、最小限の熱しか出さないため、うるさい振動をもたらすファン類も不要です。

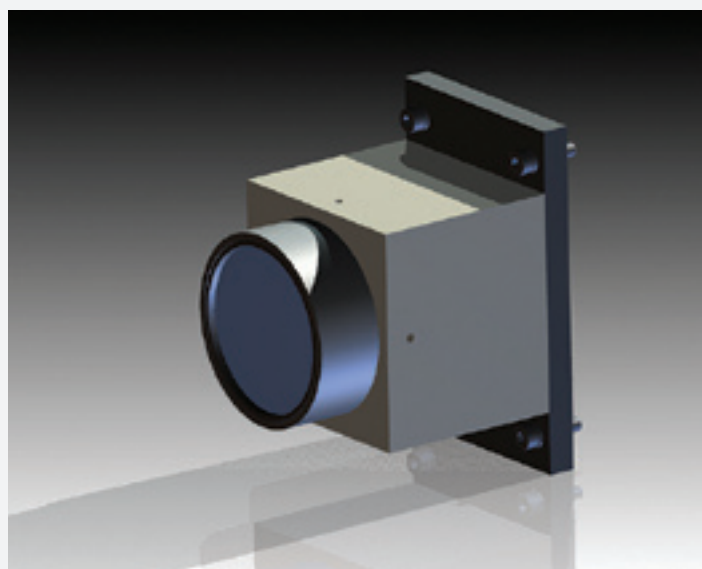

LED電源 : CLED

チャンネル当り最大800mAの、PMW(パルス幅制御)方式による輝度制御の可能な、3チャンネル定電流電源

RGB照明の3チャンネル独立の輝度制御、及び同調制御も可能

8-bitデジタル信号にて制御可能

		Optical Characteristics	
LED	Type	Super bright white LED	R, G, or B LEDs also available
	Max. light intensity	140 lm	
	Max. current	1.5 Amp	
	Min. color temp.	4500 K nm	Adjustable by setting LED current
	Max. color temp.	10000 K nm	
	Typical spectrum	See diagram	
Optical arrangement	Projection optics	Two groups: aspheric and achromatic lenses	Customization available
	Standoff distance	70 to 150 mm, adjustable	
Serial communication	Type	RS232	Auto baud rate recognition
	Intensity control	Single command word	PWM, 0 to 100%, 1% step
	Current control	Single command word	0 to 1.5 Amp. 15 mA step Adjusts color temperature
Supply voltage	Minimum	12 Volts	Current @ 12V: 3 Amp.
	Maximum	24 Volts	Current @ 24V: 1.5 Amp.

**WDI has introduced the LED illuminator for the microscopy applications. The unit consists of LED lamp head(s) with optics and 3 channel LED controller. The controller communicates with a computer via RS232 serial communication link.**

**The illuminator can be configured as:**  
Field light illuminator (also referred to as the coaxial or through the lens illuminator)  
Back-light illuminator

**Illumination Colors**

The standard light head is equipped with high brightness white LED. Other colors such as red green and blue are also available.

**Light intensity control:**

Individually programmable maximum current for each of the 3 available channels  
Pulse width modulation (PWM) assuring:  
Consistent light source temperature regardless of the brightness Energy efficiency and thus reduction of the heat dissipation  
Linear intensity control

**Exceptional brightness and color contrast:**

Illuminator optics is efficiently coupled with the microscope objective NA  
Illuminator assures sufficient excess of brightness to allow camera saturation even when specialty high magnification lenses (100x NUV 80x UV) are used  
The illuminator optics is designed to enhance the color contrast of transparent thin film structures such as TFT arrays

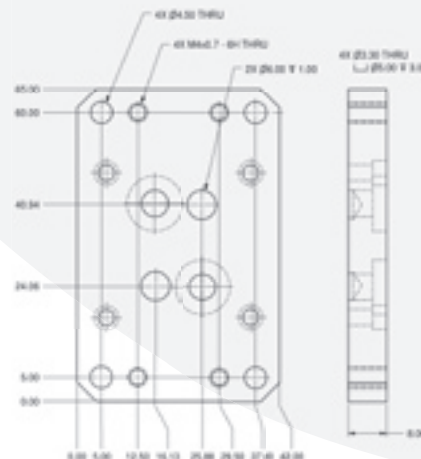
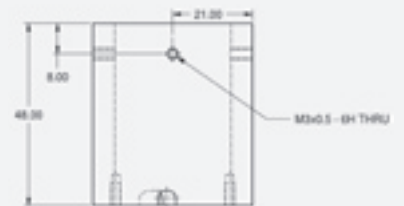

**Physical Dimensions**