

data sheet

# pc<sub>o</sub>. pixelfly™ 1.3 SWIR

versatile VIS - **SWIR** camera

**SWIR** shortwave  
infrared

resolution

**1.3 MPixel**

pixel size

**5.0 μm x 5.0 μm**

interface

**USB 3.1 Gen 1**

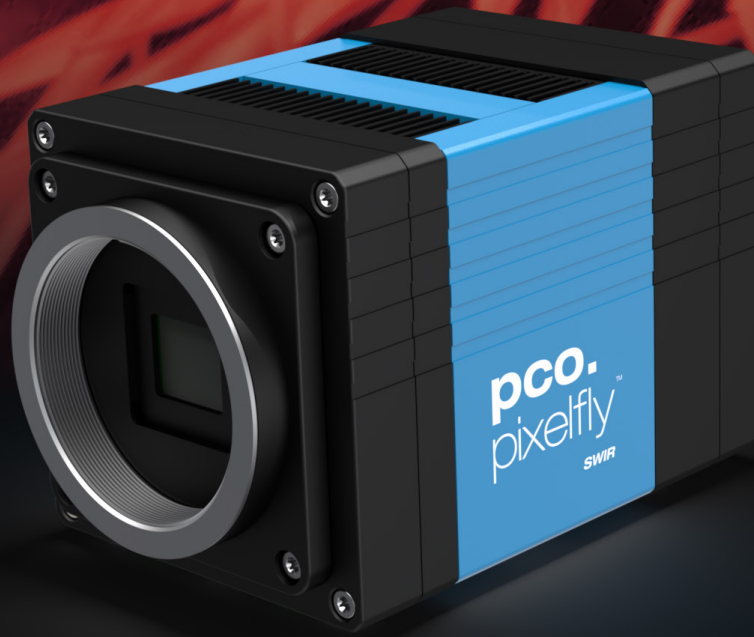

VIS & SWIR sensitivity  
350 nm to 1700 nm

TEC controlled  
sensor temperature

small pixel size  
5 μm x 5 μm

InGaAs sensor technology

long exposure times  
(due to low dark current)

max. frame rate 72 fps  
@ 1.3 MPixel

**pc<sub>o</sub>.**

An Excelitas Technologies Brand

## technical data

### image sensor

sensor technology	InGaAs
color type	monochrome
resolution (horizontal x vertical)	1280 pixel x 1024 pixel
pixel size (horizontal x vertical)	5.0 μm x 5.0 μm
sensor size (horizontal x vertical)	6.4 mm x 5.1 mm
sensor diagonal	8.2 mm
shutter type	global shutter
modulation transfer function (theoretical max.)	100.0 lp/mm
fullwell capacity	155.700 e <sup>-</sup>
readout noise (typ.)	210 e <sup>-</sup> rms
dynamic range (intra-scene)	680:1 (57.0 dB)
peak quantum efficiency	90 % @ 1200 nm
spectral range	350 nm - 1700 nm
dark current	2000 e <sup>-</sup> /pixel/s @ +5 °C sensor temperature

### frame rate table

vertical resolution reduction	frame rate
1280 x 1024	72 fps
1280 x 512	TBD
1280 x 256	TBD
1280 x 128	TBD
1280 x 16	TBD



### camera

max. frame rate @ full resolution	72.2 fps
exposure time range	20 $\mu$ s - 12 min
dynamic range A/D	12 bit
conversion factor <sup>1</sup>	41 e <sup>-</sup> /DN
pixel rate	93 MPixel/s
region of interest (ROI)	horizontal: steps of 8 columns vertical: steps of 4 rows
non-linearity	< 0.5 %
dark signal non-uniformity (DSNU)	< 147 e <sup>-</sup> rms
photo response non-uniformity (PRNU)	< 0.9 %
cooling temperature image sensor	+20 °C @ ambient + 25 °C @ humidity 70 %
cooling method	peltier with forced air, dewpoint regulated
trigger input signals	frame trigger, sequence trigger, programmable input
trigger output signals	exposure, busy, programmable output
input / output signal interface	SMA connectors
time stamp	in image (1 $\mu$ s resolution)
data interface	USB 3.1 Gen 1

<sup>1</sup> According to EMVA1288 the conversion factor equals the inverse of the system gain and can be operational mode dependent.

### quantum efficiency

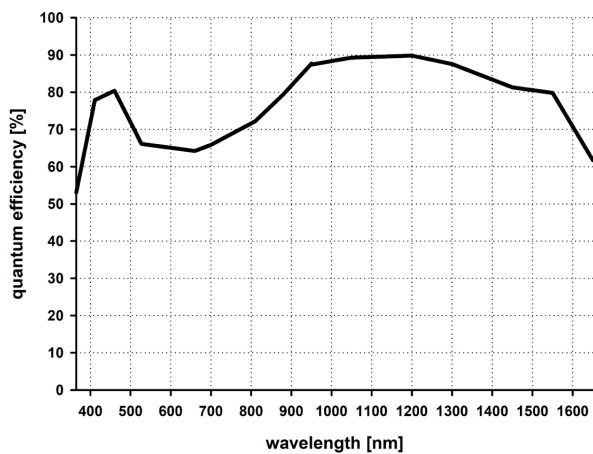

### image sensor cooling temperature vs. ambient temperature vs. relative humidity

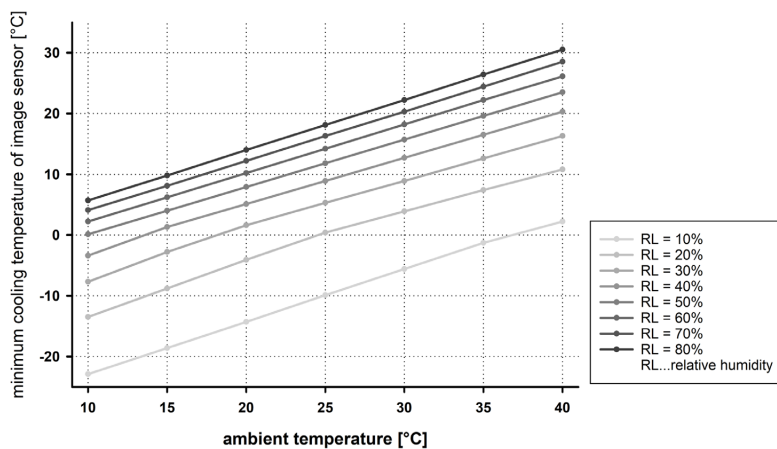

## general

<b>power supply</b>	power over USB 3.1 Gen 1
<b>power consumption</b>	typ. 7 W, max. 15 W
<b>weight</b>	680 g
<b>dimensions (height x width x length)</b>	70 mm x 70 mm x 115 mm
<b>operating temperature range</b>	+10 °C to +40 °C
<b>operating humidity range (non-condensing)</b>	10 % to 80 % (non-condensing)
<b>storage temperature range</b>	-10 °C to +60 °C
<b>CE / FCC certified</b>	yes

## optical interface

<b>direct mounting</b>	5.2 mm ±10 %
<b>lens mounting</b>	C-Mount
<b>optional lens mounting</b>	F-Mount, TFL-Mount

Configure your optical setup with our **MachVis Lens Selector** online tool.

## dimensions

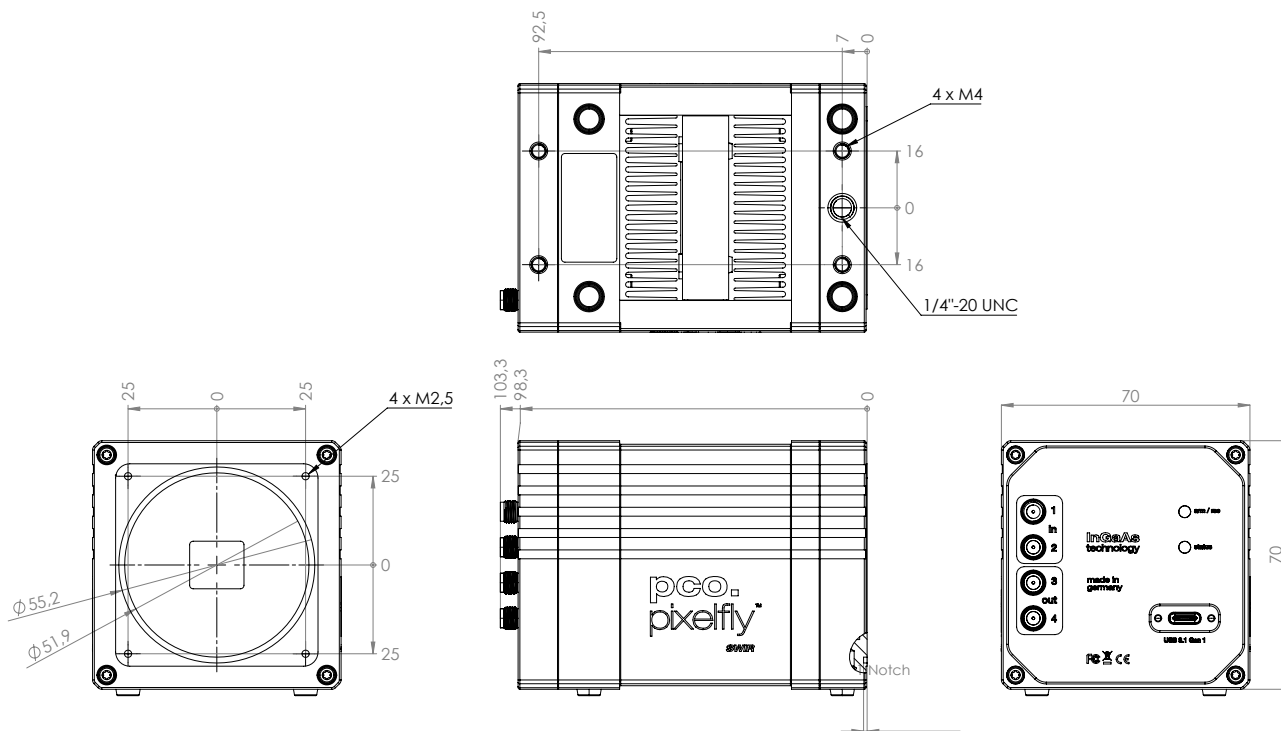

Outlines of pco.pixelfly™ 1.3 SWIR (all dimensions given in mm).

## software

Our main camera control software pco.camware is the first choice to get started with your camera. It enables full control of all camera settings and makes image acquisition and storage very easy. Using different layouts, styles and features you can customize it exactly to your needs.



### You are using a different software:

PCO cameras are also integrated in a variety of software applications. Check our homepage to find a list of all applications that support PCO cameras.



(in preparation)

### You want to create your own application for the camera:

We offer a wide range of Software Development Kits (SDK) for different programming languages, both for windows and linux. Our pco.sdk, pco.recorder and high-level SDK are designed for C/C++ apps. With pco.python, pco.matlab, pco.labview and pco.java you can control the camera in your C#, python, matlab, labview and java applications, respectively. This camera is also gen<i>cam supported.

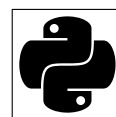
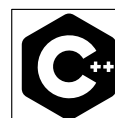
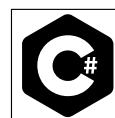
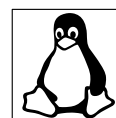
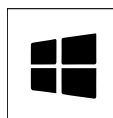

### Your use case is in the field of microscopy:

PCO cameras are also integrated in µManager.



## areas of application

bright-field microscopy | fluorescence microscopy | structured illumination microscopy (SIM) | high-speed bright-field ratio imaging | industrial quality inspection | wafer inspection | material sorting | intravital microscopy | inspection | material testing | material selection | biometrics | in-vivo microscopy | industrial packaging | waste sorting | semiconductor inspection | food processing quality control

# pco.

An Excelitas Technologies Brand

telephone:	+ 49 (0) 9441 2005 50
fax:	+ 49 (0) 9441 2005 20
postal address:	Excelitas PCO GmbH Donaupark 11 93309 Kelheim, Germany
email:	<a href="mailto:pco@excelitas.com">pco@excelitas.com</a>
web:	<a href="http://www.pco.de">www.pco.de</a> <a href="http://www.excelitas.com">www.excelitas.com</a>

