



OZ Optics

shop.ozoptics.com
www.ozoptics.com

219 Westbrook Road
Ottawa, ON, Canada, K0A 1L0

Toll-free: 1-800-361-5415
Telephone: 1-613-831-0981
Fax: 1-613-836-5089
sales@ozoptics.com

POCKET OPTICAL POWER METER

PRELIMINARY

Features

- Slim and compact
- Wide wavelength range
- Interchangeable optical connectors available
- Long battery lifetime
- Rechargeable battery or AC adaptor
- USB and Bluetooth interfaces
- OEM version with no display for embedded system
- Low cost

Applications

- Fiber optic assembling and testing
- Quality control and measurement
- Network installation
- Component and system troubleshooting
- General optical power measurement



Product Description

The new OZ Optics low cost pocket style POM-500 offers a high-resolution optical power meter with a wide dynamic range covering a broad spectrum of wavelengths. The unit is offered as a stand-alone pocket style module with built-in display and rechargeable battery. The extremely low power consumption allows extended operation in the field. A user-friendly keypad and easy-to-read back-lit display makes it well suited to most user applications. Using the USB or Bluetooth interface, the POM-500 can be controlled by a host PC using a series of simple commands.

The Pocket Optical Power Meter is also offered as an OEM module (with no built-in display) that can be embedded in a system for remote power monitoring or for long term power logging. The OEM version is offered with multiple remote interfaces: I²C, SPI and RS232, for easy data logging and reporting.

The POM-500 can accommodate a variety of standard, interchangeable screw-in receptacles: FC, SC, ST and LC are included in the package.

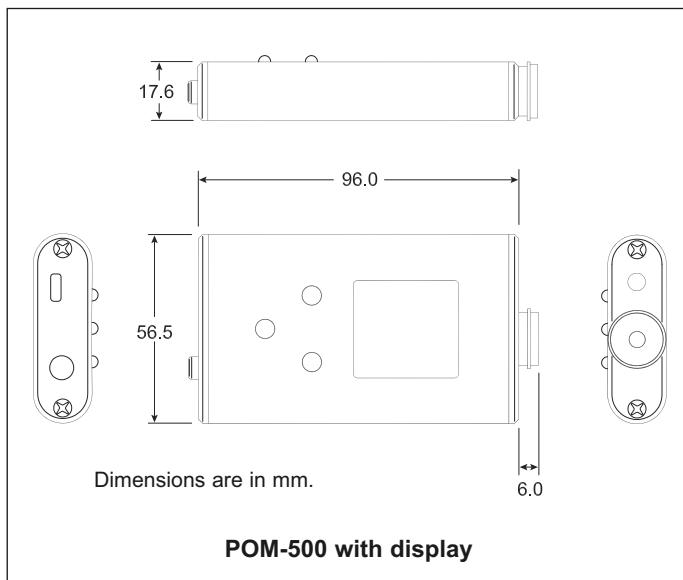

Ordering Information for Standard Parts:

Bar Code	Part Number	Description
NEW	POM-500-IR-D	Pocket Optical Power Meter with InGaAs detector, for 900–1650 nm, -60 dBm to +3 dBm dynamic range. Measurements are in mW/dBm/dB with 4 or 5 digit display. With built-in rechargeable battery, USB and Bluetooth enabled. Unit comes with FC, SC, ST and LC receptacles.
NEW	POM-500-VIS-D	Pocket Optical Power Meter with Si detector, for 450–1000 nm, -60 dBm to +3 dBm dynamic range. Measurements are in mW/dBm/dB with 4 or 5 digit display. With built-in rechargeable battery, USB and Bluetooth enabled. Unit comes with FC, SC, ST and LC receptacles.
NEW	POM-500-R-3	Interchangeable FC receptacle for POM-500 Pocket Optical Power Meter. Compatible with flat, super, ultra and angled FC connector.
NEW	POM-500-R-SC	Interchangeable SC receptacle for POM-500 Pocket Optical Power Meter. Compatible with flat, super, ultra and angled SC connector.
NEW	POM-500-R-LC	Interchangeable LC receptacle for POM-500 Pocket Optical Power Meter. Compatible with flat, super, ultra and angled LC connector.
NEW	POM-500-R-8	Interchangeable ST receptacle for POM-500 Pocket Optical Power Meter. Compatible with flat, super and ultra ST connector.

Standard Product Specifications:

Measurement range ¹	IR	-60 to +3 dBm
	VIS	-60 to +3 dBm
Wavelength range		900 to 1650 nm with IR detector. 450 to 1000 nm with visible detector.
Calibrated wavelengths	IR	1620, 1550, 1480, 1310 and 1064 nm
	VIS	980, 850, 780, 635 and 520 nm
Resolution		0.01 dB
Accuracy ²		± 5% (+0 to -50 dBm) at calibrated wavelengths using singlemode fiber and FC/PC receptacle.
Linearity ³		± 0.05 dB (+0 to -50 dBm).
Measurement units		mW, dBm, dB
Available optical receptacles		FC; AT&T-ST; SC and LC.
Sampling rate		Typical 1000 Hz
Dimensions (L x W x H) (not including receptacle)		96.0 x 56.5 x 17.6 mm 98.8 x 50.6 x 19.1 mm OEM module without display.
Weight		Typical 250 g
Communications interface		USB port, bluetooth for -D version; I ² C, SPI, and RS232 for OEM version.
Power supply		USB interface; built-in rechargeable Lithium ion battery pack.
Temperature range, Non-condensing	Operating	0 to +50 °C
	Storage	-40 to +70 °C

Notes:

¹ Maximum measurement range is dependent on the responsivity of the detector, which is related to the wavelength, and the area of the detector that is illuminated by the incoming light. Please consult OZ Optics for high power measurement.

² Measured at 23 °C.

³ Measured at 23 °C, using SM fiber terminated with FC connector at 1550 nm and 850 nm for respectively IR and Visible power meter.

Ordering Examples for Standard Parts

A customer needs to measure the insertion loss, at 1550 nm, of fibers terminated with FC/PC connectors. If he already has an optical source, then all he needs to order is the following part:

Bar Code	Part Number	Description
NEW	POM-500-IR-D	Pocket Optical Power Meter with InGaAs detector, for 900–1650 nm, -60 dBm to +3 dBm dynamic range. Measurements are in mW/dBm/dB with 4 or 5 digit display. With built-in rechargeable battery, USB and Bluetooth enabled. Unit comes with FC, SC, ST and LC receptacles.

Questionnaire:

1. What is your operating wavelength range?
2. What is the maximum power level that you need to measure?
3. What is the minimum power level that you need to measure?
4. What type of optical receptacle do you need?
5. Do you need to be able to control the power meter from a computer?
6. Do you want a unit with built-in or without display?

Ordering Information for Custom Parts

Description

Optical Power Meter

Part Number

POM-500-W-T

T: D = Standalone unit with display
O = OEM module without display

W: Wavelength range:
IR = infrared, 900 to 1650 nm
VIS = visible, 450 to 1000 nm

Description

Optical receptacle

Part Number

POM-500-R-X

X: Receptacle style:
3 = FC flat or angled
8 = AT&T-ST
SC = SC
LC = LC

Ordering Examples for Custom Parts:

A customer wants to install a power meter to log power continuously at 1550 nm, which has an LC connector on the end of a fiber. He can do this by ordering the following part:

Part Number	Description
POM-500-IR-O	OEM Pocket Optical Power Meter with InGaAs detector, for 900–1650 nm, -60 dBm to +3 dBm dynamic range. Measurements are reported in mW/dBm/dB. Device comes with RS232, USB, I ² C and SPI interfaces enabled. Unit comes with FC, SC, ST and LC receptacles.

Frequently Asked Questions (FAQs)

Q: I need to measure a noisy signal. Can I do this?

A: Yes. The POM-500 allows the user to set the length of an averaging queue, which will filter much of the noise to provide a steady average reading.

Q: Can I use the OEM version in my remote system?

A: Yes. The OEM power meter is well suited to being integrated on customer systems. Unit comes with multiple remote interface ports, and the customer can also add his own calibration table over the factory calibration table.

Q: How long will the rechargeable battery last between charges?

A: Rechargeable battery is only available with the built-in display version, this unit can be run for up to 150 hours on a single charge. This will vary, depending on the power level being measured. Using the backlight continuously will increase the power consumption and drain the battery faster. For maximum battery life, the backlight should only be turned on when it is required.

Q: What is the recommended calibration period?

A: We recommend calibration of the meter every 12 months.

