



OZ Optics

shop.ozoptics.com
www.ozoptics.com

219 Westbrook Road
Ottawa, ON, Canada, K0A 1L0

Toll free: 1-800-361-5415
Telephone: 1-613-831-0981
Fax: 1-613-836-5089
sales@ozoptics.com

BENCHTOP DIGITAL MULTICHANNEL ATTENUATOR

Features

- High power handling (up to 2 watts)
- Wide attenuation range (up to 60 dB)
- Low PDL and wavelength dependency
- Low insertion loss and backreflection
- High resolution
- Rugged and compact design
- Can be calibrated for dual wavelengths, (1300–1550 nm) or calibrated for telecom C and L band applications. It can also be calibrated for up to four individual wavelengths per channel
- Wide wavelength range (350–2050 nm)
- Wide range of receptacles
- Blocking technique for singlemode and polarization maintaining; neutral density filter technique for multimode fiber applications
- Computer interface (USB as standard)
- Your choice of up to four attenuators per unit
- Optional integrated power monitoring for precise output power control

Applications

- Bit error rate testing
- Trouble shooting receivers and other active fiber optic components
- Simulating long distance fiber transmission
- Design of fiber optic transmitter/receiver circuitry
- Power meter linearity checks
- Power setting

Product Description

OZ Optics offers a compact, rugged and low cost benchtop digital multichannel attenuator with high resolution, high attenuation range, and high power handling (blocking technique only). These attenuators have low insertion loss, low backreflection, low PDL and flat wavelength response. These units can be calibrated for up to 4 wavelengths for each attenuator, for C or L bands. Alternatively the unit can be calibrated for a continuous range. By using interpolation between the calibration wavelengths, the unit is capable of providing accurate attenuation levels over a continuous, broad range of wavelengths.

OZ Optics' multichannel attenuators are ideal for use in bit error rate testing, troubleshooting receivers and other active fiber optic components, power meter linearity checks, simulating long distance fiber transmission, and power setting. A computer interface allows users to access or remotely control the unit through a PC.

OZ Optics provides attenuators that use either singlemode, multimode or Polarization Maintaining (PM) fiber. In general, OZ Optics uses polarization maintaining fibers based on the PANDA fiber structure when building polarization maintaining components and patch cords. However, OZ Optics can construct devices using other PM fiber structures. We do carry some alternative fiber types in stock, so please contact our sales department for availability. If necessary, we are willing to use customer supplied fibers to build devices.



MCDD-1000 Front View

Standard Product Specifications

Fiber Type		SM/PM	MM
Available wavelengths		350–2050 nm	350–2050 nm
Insertion loss ¹ (IL)	Typical	1.0 dB	2.0 dB
	Maximum	2.0 dB	4.0 dB
Attenuation range ²		IL to 60 dB	IL to 40 dB
Attenuation resolution ³		0.01 dB	
Wavelength dependence of attenuation ⁴	from 1300 nm to 1550 nm	up to 0.3 dB	
	from 1520 nm to 1570 nm	up to 0.1 dB	
Polarization dependent loss ¹	Typical	up to 0.05 dB	
	Minimum	up to 0.01 dB	
Return loss ¹		40, 50 or 60 dB	35 dB
Speed ⁵		100 ms	
Repeatability of attenuation setting	up to 10 dB	±0.03 dB	
	up to 30 dB	±0.10 dB	
	up to 40 dB	±0.3 dB	
Accuracy ⁶	up to 40 dB	±0.3 dB	
	40 to 55 dB	±0.5 dB	
	55 to 60 dB	±1.0 dB	
Power Supply		Universal 110/220V AC 50/60 Hz, 40 W	
Maximum optical power		up to 2 W ⁷	up to 50 mW
Computer interface		USB	
Polarization extinction ratio (for PM fiber) ¹		20, 25 or 30 dB	
Dimensions ⁸ (L x W x D)		280 x 300 x 100 mm	
Weight		8.8 lb + 0.55 lb/channel (4 kg + 0.25 kg/channel)	
Operating temperature		14°F to 131°F (-10°C to 55°C)	
Storage temperature		-22°F to 158°F (-30°C to 70°C)	
Display		Touch screen	
Certifications	Standard	Description	
	CSA-C22.2 NO. 61010-1-12	Safety requirements for electrical equipment for measurement, control, and laboratory use - Part 1: General requirements - Third Edition; Update No. 1: July 2015; Update No. 2: April 2016	
	UL 61010-1	UL Standard for Safety Electrical Equipment For Measurement, Control, and Laboratory Use; Part 1: General Requirements - Third Edition; Including Revisions through July 15, 2015	
	CE	Certifies the product meets all EU health, safety and environment requirements including the latest RoHS & REACH compliance, which ensures consumer safety	

Ordering Examples For Standard Parts

A customer needs to control the attenuation by using a computer for 4 channels at 1550 nm. He needs LC/PC connectors with 40 dB or better return loss for singlemode fiber. He should order the following part:

Bar Code	Part Number	Description
61658	MCDD-1000-4-LC-1550-9/125-S-40	Benchtop digital multichannel attenuator with 4 channels for 1550 nm with 9/125 micron singlemode fiber and LC/Super PC receptacles.

OZ Optics welcomes the opportunity to provide custom designed products to meet your application needs. As with most manufacturers, customized products do take additional effort so please expect some differences in the pricing compared to our standard parts list. In particular, we will need additional time to prepare a comprehensive quotation, and lead times will be longer than normal. In most cases non-recurring engineering (NRE) charges, and/or lot charges will be necessary. These points will be carefully explained in your quotation, so your decision will be as well-informed as possible. We strongly recommend buying our standard products.

Questionnaire For Custom Parts

- How much power will be transmitted through the attenuator?
- What type of fiber do you wish to use?
- What is the worst acceptable return loss?
- Will this attenuator be used in Europe or in the United Kingdom?
- Are there any special performance requirements that you need to meet?
- What wavelengths do you want the attenuator calibrated at?

Multichannel Variable Attenuator: **MCDD-1000-CH-X-W-a/b-F-LB(-OPT)**

CH = Channel count (1 to 4).

X = Receptacle code
 3S = Super NTT-FC/PC
 3U = Ultra NTT-FC/PC
 3A = Angled NTT-FC/PC
 LC = Super LC/PC
 LCU = Ultra LC/PC
 LCA = Angled LC
 8 = AT & T-ST SC = SC
 SCA = Angled SC
 See the *Standard Tables* data sheet for other connectors.
https://www.ozoptics.com/ALLNEW_PDF/DTS0079.pdf

W = Wavelength: Specify in nanometers: Example: 1300/1550 for standard telecom wavelength range.

a/b = Fiber core/cladding sizes, in microns 9/125 for 1300/1550 nm SM fiber.
 See the *Standard Tables* data sheet for other standard fiber sizes.
https://www.ozoptics.com/ALLNEW_PDF/DTS0079.pdf

Note: Add -LL to the part number for 0.6 dB typical insertion losses for 60 dB return loss, < 1 dB for the rest of the attenuators.

OPT = Options
 OPM=Optical Power Monitoring (Standard version for input power from 0.65 μ W to 100 mW)
 OPM-HP=Optical Power Monitoring (High power version for input power from 100 mW to 1 W for 980 nm and over). Please contact OZ Optics if you need higher power levels.
 LL=Low Insertion Loss (see note)
 HP=High Power (non OPM versions)

LB = Backreflection level: 40, 50 or 60 dB for singlemode fibers, 35 dB for MM fibers

E = Fiber type:
 M=Multimode
 S=Singlemode
 P=Polarization Maintaining

Ordering Examples For Custom Parts

A customer wants to order a 4 channel benchtop digital multichannel attenuator to be calibrated at 1300 nm and 1550 nm, using singlemode fiber and FC/UPC receptacles with 50 dB backreflection and ≤ 1 dB insertion loss. The part number should be: MCDD-1000-4-3U-1300/1550-9/125-S-50-LL.

Frequently Asked Questions (FAQs)

Q: What advantages or disadvantages does the beam blocking version have over the neutral density versions.

A: The beam blocking technique is naturally suited for high power applications, and can achieve greater attenuation levels. The neutral density version shows less mode dependence or modal noise in multimode applications.

Q: What do you mean by mode dependence and modal noise?

A: The term multimode means there is more than one path for light to travel inside a single fiber. These paths are known as modes. It does not mean the unit consists of multiple fibers in a bundle. When coherent laser light is coupled into multimode fiber, the output shows speckles. Bending the fiber causes the speckle pattern to change. If the losses in a system depend on which modes are excited, then changing the modes excited in the fiber changes the output power. This is known as modal noise. If the source being used is an LED, then one does not see speckles, and modal noise is not an issue. However, for laser sources, modal noise is an issue.

When blocking style attenuators are used with multimode fiber, some modes are blocked, while others are transmitted. This can produce 1 dB or greater modal noise fluctuations with coherent sources. A variable attenuator using a neutral density filter is not as strongly affected by modal noise. However, neutral density filter attenuators offer lower attenuation range (around 40 dB) and can only handle about 50 mW of power.

Q: I ordered an attenuator with 60 dB return loss but when I measured it my return losses are higher. Why?

A: If you ordered an attenuator with 60 dB return loss with connectors, the backreflection will depend on what grade of connector you selected for your fibers. Typically only angle polished (APC) style connectors will give the desired return

losses. The device itself has 60 dB return loss (i.e. if you cut off the connectors and measured the return loss you will see it above 60 dB) but if you picked only an ultra PC finish, then you will see a higher level of backreflection.

Q: How many different wavelengths can be calibrated on a single unit? How will it affect accuracy? How will it affect costs?

A: One option is to have the unit calibrated at discrete wavelengths. Up to three wavelengths can be calibrated up to 60 dB. Optionally up to four wavelengths can be calibrated up to just 50 dB. Calibration sources are only available for certain wavelengths.

Note that over standard wavelength ranges such as from 1520 to 1620 nm, a unit will experience about 0.1 dB variation of attenuation versus wavelength.

Another option is to have a unit calibrated over a wavelength range. This process calibrates the unit at many more wavelengths, but at lower resolution, and then uses interpolation to produce a specific attenuation at a user defined wavelength. Either six or twelve wavelengths can be used for calibration, to reduce the variation to less than 0.03 dB over the range.

Q: How often should we send the unit for re-calibration?

A: We recommend yearly calibration.

Q: Can I order a unit having different type of attenuators?

A: Yes you can. For example, you can have first channel with SM, next channel with MM, and last 2 channels PM fiber, and each can have a different wavelength. You can change the fiber type and wavelength for as many channels as you need (up to 4 channels).

Application Notes

Sample Application: Signal Strength Monitoring and Control System

As illustrated in Figure 1 below, light from a transmission module is sent through a MCDD style attenuator before entering the transmission line. A 99:1 splitter is used to tap off a small monitor signal. This signal is measured with a photodiode module, which produces a digital representation of the light intensity. Based on this feedback, the computer adjusts the attenuator to set the output signal at the optimum intensity.

Wavelength Calibration And Accuracy

The benchtop digital multichannel attenuator is normally calibrated at the wavelength or wavelengths specified in the part number (Note: Parts with the wavelength specified as 1300 are in fact calibrated at 1310 nm). Standard models of the digital attenuator allow one to select between one or two calibration wavelengths. For DWDM applications, one normally orders the device calibrated for 1550 nm. Variation in the attenuation with wavelengths over the C and L bands is minimal (<0.1 dB over the C and L bands for up to 30 dB attenuation).

For some applications however, people want multichannel attenuators that are calibrated for all wavelengths within a certain range. This can be accomplished as well. To achieve this the unit is calibrated at up to 12 different wavelengths, evenly spaced over the range in question. Two wavelengths are calibrated to 0.01 dB resolution, while the other wavelengths are calibrated to 0.1 dB resolution. The unit will use interpolation to determine the proper setting to obtain a specific attenuation at a specific wavelength. With this technique the attenuation precision is improved to better than 0.03 dB over the entire wavelength range for up to 30 dB attenuation.

OZ Optics utilizes a number of highly stable sources for calibrating digital variable attenuators for different wavelengths. These include single wavelength sources for 830, 1064, 1310, 1480, 1550, and 1625 nm, as well as tunable sources for the C and L bands (1520–1620 nm).

Please bear in mind that the calibration process does require time to execute. As a result, the more wavelengths that you ask an attenuator to be calibrated against, the more expensive the unit will become. At the time of preparing this data sheet, calibration fees were set at \$150 USD for each additional wavelength requested.

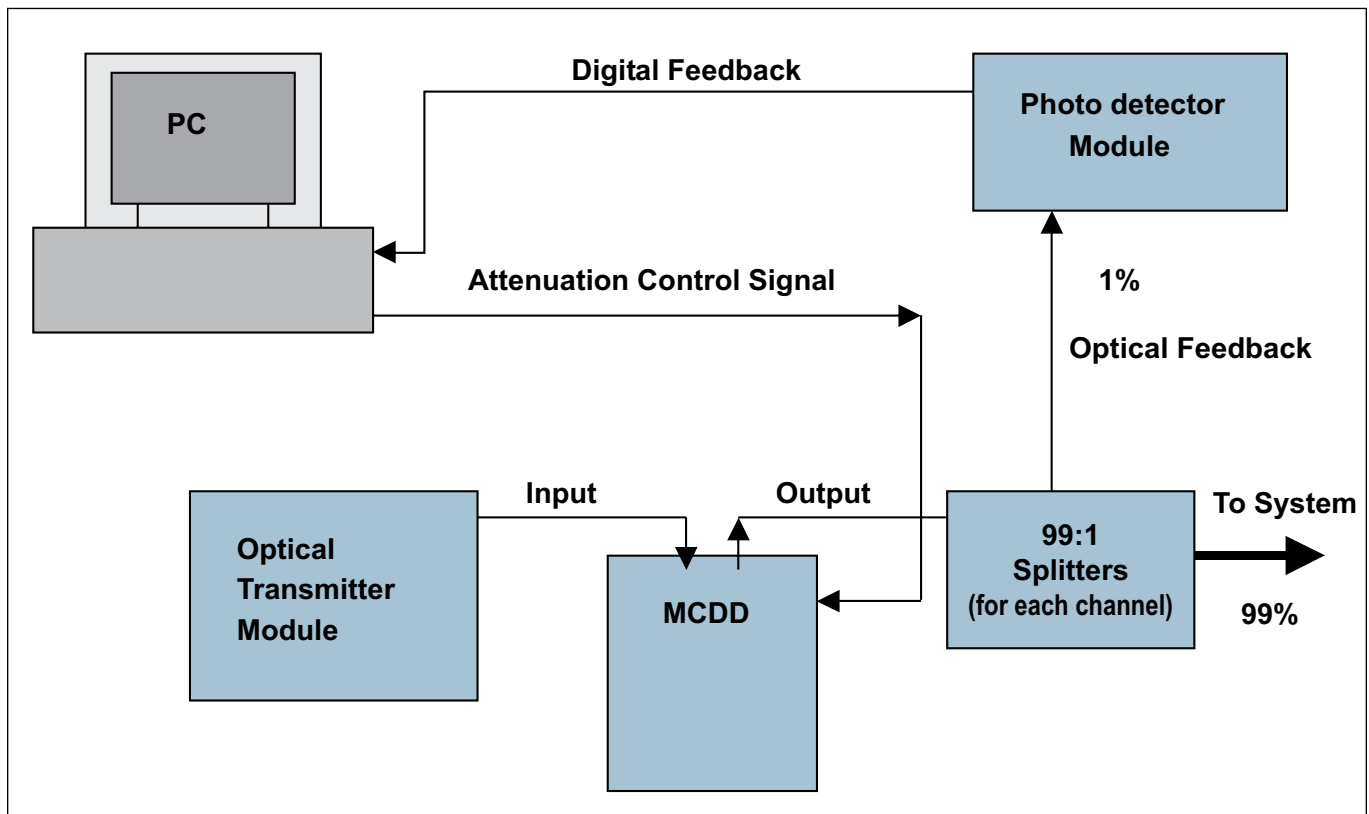

Figure 1.