

Polarization Maintaining Coupler



The polarization maintaining filter coupler can either split the light from an input PM fiber between 2 output PM fibers, or can combine light signals from 2 PM input fibers into a single PM output fiber. The device can be used to split high power linearly polarized light into multiple paths without perturbing the linear state of polarization (SOP). It can also be used as a power tap to monitor signal power in a PM fiber system without disturbing the linear SOP of the light propagating in the PM fiber. Applications include PM fiber interferometers, power sharing in polarization sensitive systems, and signal monitoring in PM fiber systems. The rugged stainless steel package is designed for high optical performance and stability. This compact device offers low excess insertion loss, low back reflection, and high extinction ratio. Split ratios from 1 to 50% are available.

Specifications:

Operating Center Wavelength	1550 nm, 1310 nm		1064 nm	
Operating Bandwidth	±40 nm		±20 nm	
Type	1 x 2	2 x 2	1 x 2	2 x 2
Max. Excess Loss ¹	0.7 dB	1.0 dB	0.8 dB	1.2 dB
Max. Uniformity	0.6 dB	0.8 dB	0.6 dB	0.8 dB
Min. Extinction Ratio ²	20 dB	18 dB	20 dB	18 dB
Return Loss	50 dB		Split Ratio Tolerances:	
Split Ratio	1 ~ 50%		1 x 2	2 x 2
Optical Power Handling	300 mW min.		99/1:	± 0.2% ± 0.2%
Operating Temperature	-5 to 70 °C		98/2:	± 0.4% ± 0.4%
Storage Temperature	-40 to 85 °C		95/5:	± 1% ± 1%
Fiber Type	PM fiber		90/10:	± 2% ± 2%
Dimensions	Pigtailed: Ø 5.5 × 35 mm NoTail: 3.5" (L) × 1.5" (W) × 5/8" (H)		50/50:	± 7.5% ³ ± 10%

Notes: Values are referenced without connectors

1. Excess loss for NoTail™ version is < 0.1 dB higher than for the corresponding pigtailed version, excluding connectors.

2. Extinction ratio can be higher for fast-axis blocked version.

3. ± 8% for 1064 nm version.

Features:

- Compact size
- Low insertion loss
- Low back reflection
- Rugged design

Applications:

- Power sharing in PM systems
- Power monitoring in PM systems
- PM fiber interferometers
- R&D laboratories

Tech Info: p. 223

Dimensions:

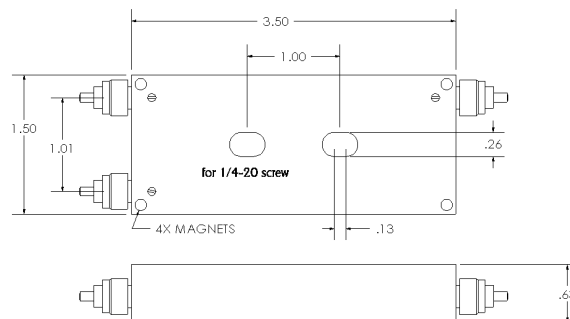
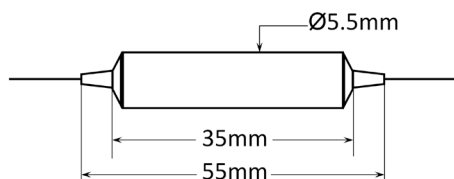

Ordering Information:

Visit our website at www.generalphotonics.com for detailed configuration information.

