

# **MPO 12F Tester**

## **Specification**

### **&**

## **Operating Manual**

2016 Ver F

## 1. Description:

The MPO Tester is a very useful tool designed for checking the defects of a MPO arrayed fiber cable or MPO Connector. The MPO emits a visible 650 nm wavelength visible red laser light through fiber optic cables, then if there are breaks or defects in the fiber will refract the light, creating a bright glow around the faulty area.



The LD output signal can be all 12 Fibers switched to CW Mode to obtain different visual effects.

## 2. Features:

- Easy to check fiber faults by using 650 nm visual red laser
- Range: visibility up to SMF or MMF Fiber 1 km
- 12F MPO Connector for testing additional
- Highly effective power circuits designed for stable laser power
- Operating in Continuous Wave Mode or Circular Mode or Manual Mode
- Driven by external USB with power bank battery

## 3. Specification

Laser Class	Class 2M
Wavelength	650 nm $\pm$ 10 nm @ 25°C
Spectral Width	< 10 nm
Output Power	> 0.4 mW @ 25°C into 9 $\mu$ m fiber
Emitting Range	Visibility up to 1 km
Operating Temp.	0°C ~ 50°C
Storage Temp.	0°C ~ 70°C
Dimension	168 x 109 x 33 mm

## 4. Dimension ( in mm )

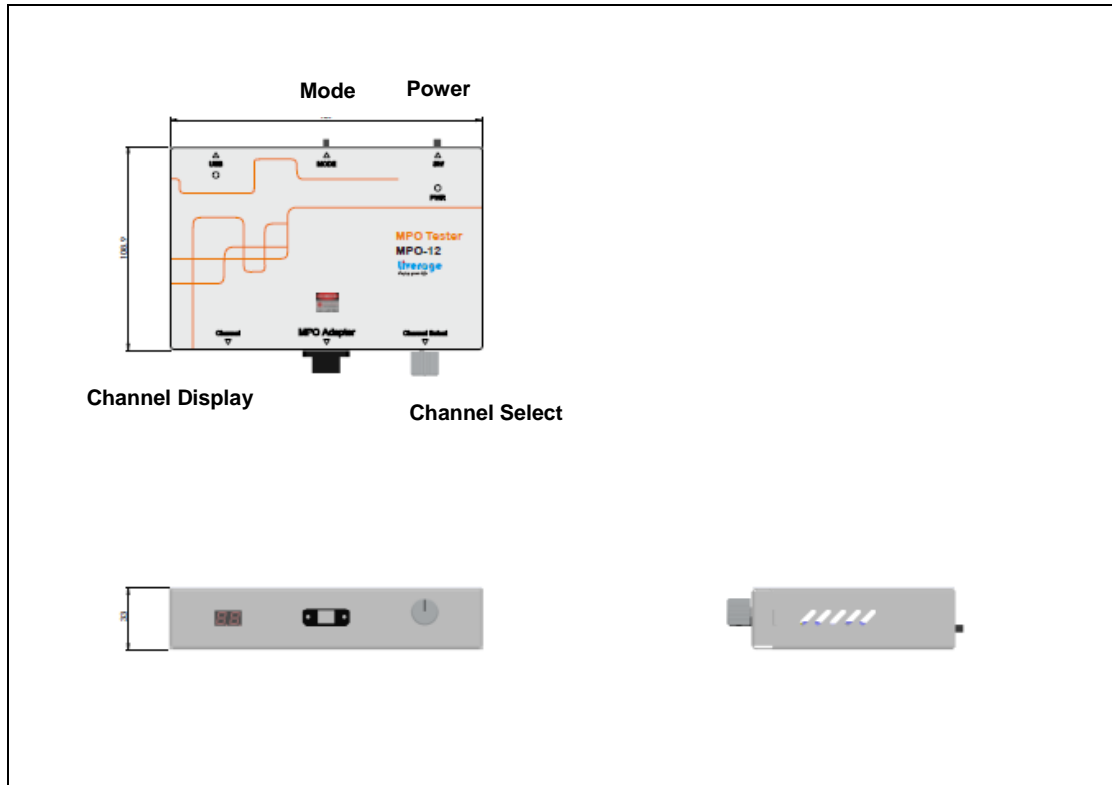

## 5. Operating Manual

1. To connect MPO Tester to USB to charge the internal battery.
2. Connecting the MPO fibers (DUT, Device Under Test ) to the MPO Tester Adapter.
3. Turn on ( Power Switch ) the MPO Tester
4. You can switch the Mode button to CW ( Continuous Wavelength ) Mode or Circular Mode or Manual Mode.
5. To check if the MPO fibers all shown red dots, that means, the MPO fibers performed well and fine.
6. To turn off ( Power Switch ) the MPO Switch
7. To disconnect the DUT for MPO Adapter.
8. To disconnect the USB.
9. To store the MPO Tester properly.

### **Warning:**

**Laser Product!**

**Please do not stare at the laser beam directly.**

**To shut off the Laser urgently, please turn off the Switch or to cover the cap directly.**

## 6. Maintenance

Like any other type of electronic equipment, this MPO Tester should be kept away from water, high humidity, dust, electricity, and environments of extreme temperatures. Do not drop this tool on any hard surface. Internal modification of any of the MPO Tester components can cause a malfunction and will invalidate the manufacturer's warranty.

## 7. Warranty

The manufacturer warrants this product to be free of defects in workmanship and materials for a period of 1 year after purchase. This warranty is solely limited to the repair or replacement of the original parts. All other costs are the sole responsibility of the owner. This warranty does not cover any defects, damage, or deterioration due to misuse, alteration, or negligence.

## 8. Ordering Information:

Part Number	Description		
	Wavelength	Cores	Output Power
<b>S2010121650</b>	<b>650 nm</b>	<b>12F</b>	<b>&gt; 0.4 mW</b>

## 9. Service Contacts

Please contact us:

**Liverage Technology Inc.**  
**3F-5, No. 30 Taiyuan Street,**  
**Chupei City, Hsinchu County 302,**  
**Taiwan**

TEL: +886-3-5525268

FAX: +886-3-5525388

e-mail: [sales@liverage.com.tw](mailto:sales@liverage.com.tw)

<http://www.liverage.com.tw>