

C-Band 10 GHz LiNbO₃ Phase Modulator PM10-C

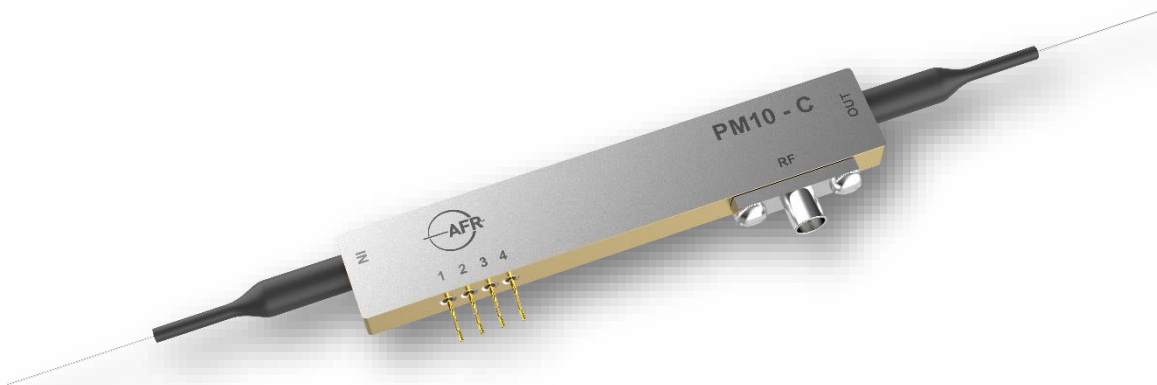

AFR broadband phase modulator combine high linearity with low driving voltage and small footprint, covering all the frequency range up to 10 GHz.

Key Features

- Operating at C-Band
- Z-Cut LiNbO₃
- Low Drive Voltage Compatible With Commercially Available Drivers
- Low Optical Insertion Loss
- Smooth Frequency Response up to > 10 GHz

Applications

- FM Spectroscopy
- Frequency Shifting
- Laser Linewidth Broadening
- Laser Beam Combining
- Quantum Key Distribution
- Interferometric Fiber Sensing

Performance Characteristics

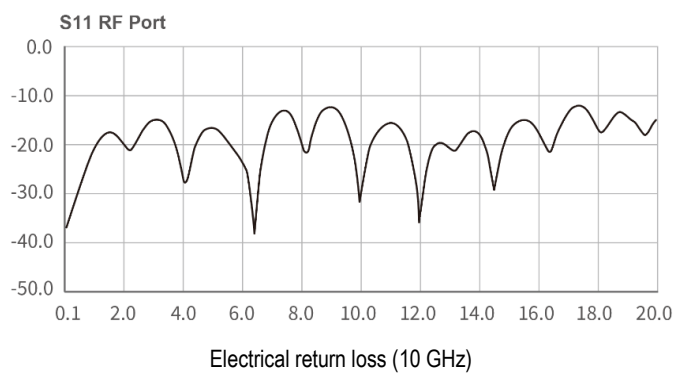

Absolute Maximum Ratings

Parameters	Conditions	Min.	Max.	Unit
Maximum Input Power (Electrical)	RF port AC coupled	-	28	dBm
Maximum Input Power (Optical)	CW	-	20	dBm
Operating Case Temperature	-	0	+ 70	°C
Storage Temperature	-	- 40	+ 85	°C
Operating Humidity	-	5	85	%
Leads Soldering Temperature	-	-	250	°C
Leads Soldering Time	-	-	10	s
Maximum Operating Temperature Variation Rate	-	-	1	°C/min

Optical and Electrical Specifications

Parameters	Conditions	Min	Typ.	Max	Unit
Optical					
Operating Wavelength Range	-	1530	-	1565	nm
Insertion Loss, IL	No connectors	-	2.5	3.5	dB
	With connectors	-	3.0	4.0	
Optical Return Loss, RL ¹	No connectors	40	45	-	dB
Polarization Dependent Loss ¹	-	5	10	-	dB
Electrical					
S ₂₁ Electro-optic Bandwidth	- 3 dBe	10	12	-	GHz
ΔS ₂₁ Ripple	-	-	0.5	1.0	dB
S ₁₁ Electrical Return Loss	-	-	- 15	- 10	dB
V _π RF Voltage	@ 50 kHz	-	4	5	V
	@ 10 GHz	-	6	7	V
RF Input Impedance	-	-	50	-	Ω

¹ Without optical connectors. Adding connectors will increase IL by 0.5 dB, reduce RL by 5 dB.
 All requirements at T_{op} = 25 °C, wavelength 1550 nm and BOL unless otherwise specified.

Pinout and Fiber Specifications

RF Connector	GPO male
Ground	LEAD pins
Input Fiber	Corning/Fujikura PM15-P-8/125-UV/UV400 (Panda fiber), L1 (900 μm loose tube fiber without connector) > 1.5 m & L2 (bare fiber) ≥ 5cm, or >1.4 m 900 μm loose tube fiber with connectors
Output Fiber	Corning/Fujikura PM15-P-8/125-UV/UV400 (Panda fiber), L1 (900 μm loose tube fiber without connector) > 1.5 m & L2 (bare fiber) ≥ 5 cm, or >1.4 m 900 μm loose tube fiber with connectors
Minimum Bending Radius	15 mm

Mechanical Outline

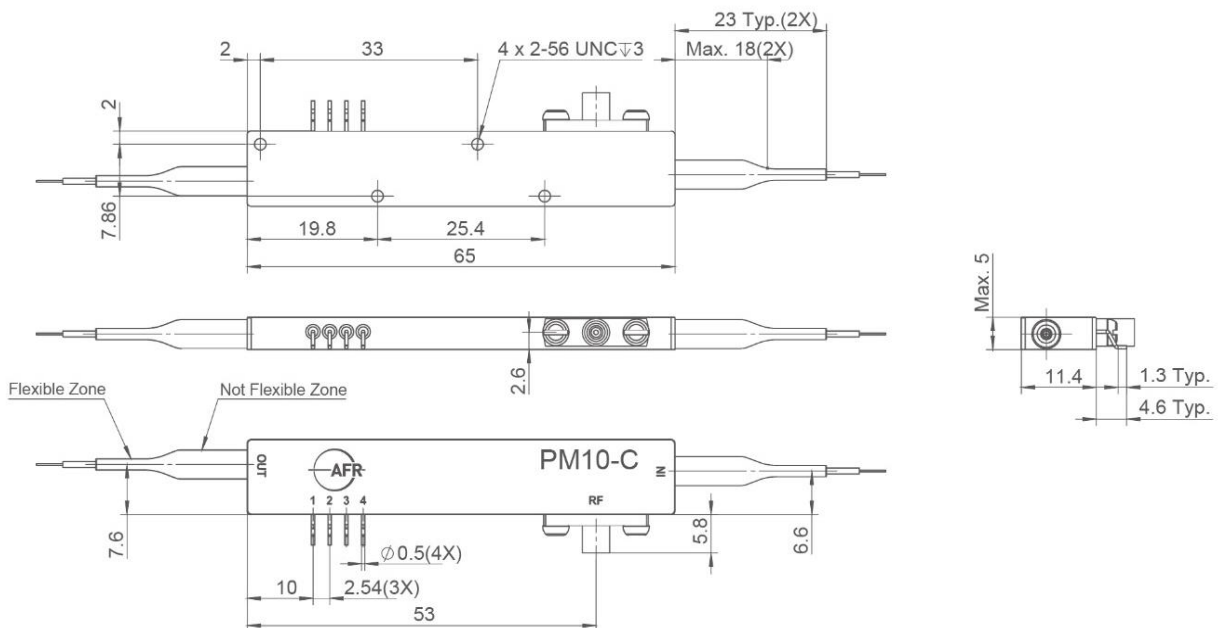

* All dimension measured in mm. L1 is fiber length with 900 μm loose tube. L2 is length of bare fiber.

Pinout Information

Pin	Name	Description
1	GND	Ground
2	GND	Ground
3	GND	Ground
4	GND	Ground
5	RF	RF Input (GPO male)

RoHS Compliance

This series of modulators are RoHS compliant.

Reliability Requirements

The PM10-C is designed to meet Telcordia GR-468-Core and GR-326 requirements.

Ordering Information:

For more information on this product and its availability, please contact your local AFR account manager or AFR directly at sales@fiber-resources.com.

Product Description	Part Number
C-Band 10 GHz LiNbO ₃ Phase Modulator, PM10-C [PM400 fiber, Corning/Fujikura PM15-P-8/125-UV/UV400, PMF(Black)-PMF(Black), > 1.5 m 900 µm loose tube fiber + > 5 cm bare fiber, no connectors]	792001550
C-Band 10 GHz LiNbO ₃ Phase Modulator, PM10-C [PM400 fiber, Corning/Fujikura PM15-P-8/125-UV/UV400, PMF(Black)-PMF(Black), > 1.5 m 900 µm loose tube fiber, FC/UPC connectors]	792001551



Advanced Fiber Resources (Zhuhai) Ltd.
No.399, Chuangxin 3rd Road, Tangjia, Zhuhai
Guangdong, China 519080
Tel: + 86 (756) 3898088

Advanced Fiber Resources (Hong Kong) Ltd.
Room 1002, 10/F., Ho Lik Centre,
66A Sha Tsui Road, Tsuen Wan, N.T.
Hong Kong
Tel: + 852 24932026

E-mail: sales@fiber-resources.com