

60W CW High Power Stacks

Part Number: MCS056

1-BAR

- High Power Stack
- Available With Up To 64 Bars Per Stack
- Available Wavelengths (790-1550nm)



OPTICAL CHARACTERISTICS

PARAMETER	CONDITIONS	MIN	TYP	MAX	UNITS
CW Power Output	25°C Heat Sink	60	---	---	W
Operating Current	60W at 25°C Heat Sink	---	68	75	A
Threshold Current	25°C Heat Sink	---	13	15	A
Center Wavelength	60W at 25°C Heat Sink	---	808	---	nm
Wavelength Tolerance	60W at 25°C Heat Sink	---	± 3	---	nm
Spectral Width FWHM	60W at 25°C Heat Sink	---	2.5	4.0	nm
Wavelength Shift	---	0.23	0.25	0.27	nm/°C
Beam Divergence FWHM (unlensed)	---	---	40x10	42x12	° x °
Beam Divergence FWHM (lensed)	---	---	0.25x10	0.5x10	° x °

ELECTRICAL CHARACTERISTICS

PARAMETER	CONDITIONS	MIN	TYP	MAX	UNITS
Series Resistance	25°C Heat Sink	2	5	7	m ohms
Operating Voltage	25°C Heat Sink	---	1.95	2.10	V

COOLING REQUIREMENTS

PARAMETER	CONDITIONS	UNITS
Type	Deionized water with deionizer cartridge	---
Resistivity	0.5 ± 0.2	M ohms
Flow Rate	0.10 ± 0.002	gpm
Pressure	minimum 40, maximum 80	psi
Particle Filter	≤ 5	μ
PH Level	7.5 ± 0.5	---

ABSOLUTE MAXIMUM RATINGS

PARAMETER	CONDITIONS
Reverse Current	0 A
Reverse Voltage	0 V
Operating Temperature Range ⁽²⁾	15°C or to 35°C
Storage Temperature Range	-20°C to 80°C

NORTHROP GRUMMAN

NOTES

(1) These specifications apply for operation at 808nm. Other wavelengths available upon request.

(2) A dry nitrogen environment should be provided by the user when storing and operating at temperatures below ambient dew point.



光技術をサポートする

株式会社オプトサイエンス

<http://www.optoscience.com>

東京本社 〒160-0014 東京都新宿区内藤町1番地 内藤町ビルディング
TEL:03(3356)1064 FAX:03(3356)3466 E-mail:info@optoscience.com
大阪支店 〒532-0011 大阪市淀川区西中島7-7-2 新大阪ビル西館
TEL:06(6305)2064 FAX:06(6305)1030 E-mail:osk@optoscience.com
名古屋営業所 〒450-0002 名古屋市中村区名駅2-37-21 東海ソフトビル
TEL:052(569)6064 FAX:052(569)8064 E-mail:ngo@optoscience.com

MECHANICAL CHARACTERISTICS

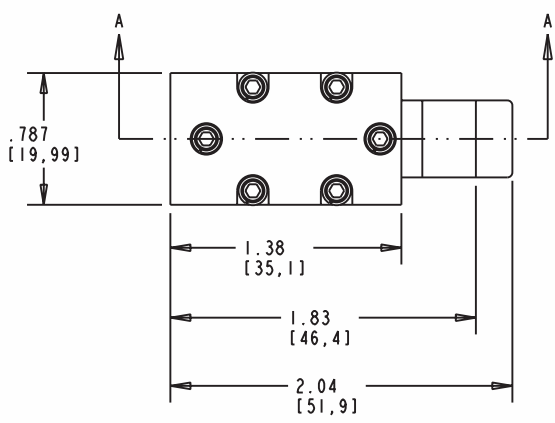
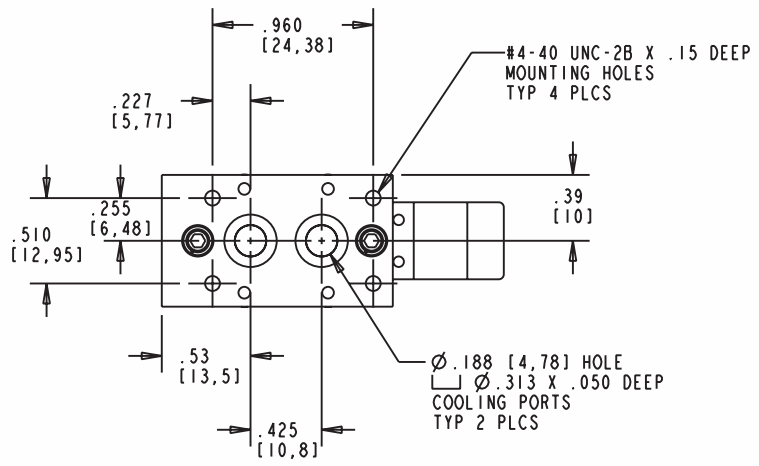
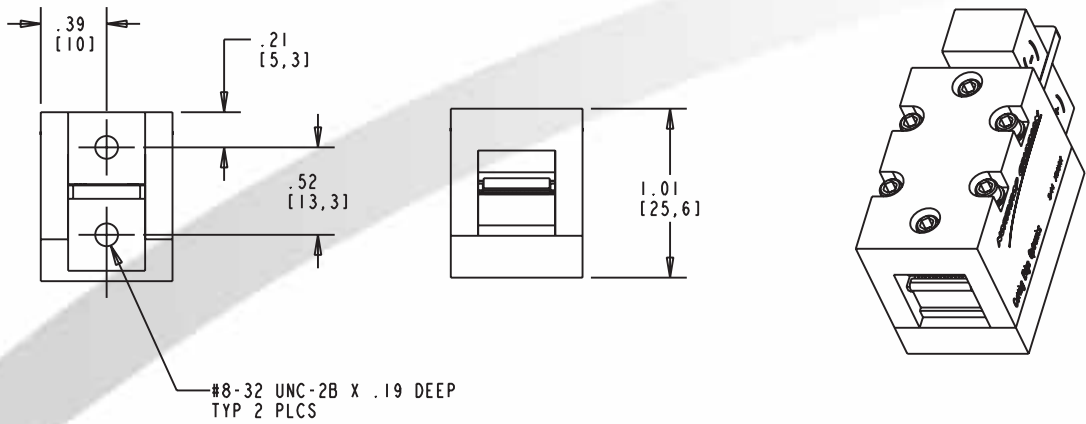

Copyright © 2006 Northrop Grumman Cutting Edge Optronics
All Rights Reserved. Northrop Grumman Cutting Edge Optronics reserves the right to change product design and specifications at any time without notice.

No license is granted by implication or otherwise under any patents or patent rights of Northrop Grumman Cutting Edge Optronics or others.

No responsibility is assumed for the use of these products, nor for any infringement on the rights of others resulting from the use of these products.

Information contained herein is believed to be reliable and accurate.

This Product is covered by one or more of the following Patents: 5,898,211 5,985,684 5,913,108 6,310,900 Other US and Foreign Patents Pending.

Laser diode product components are intended for use in a user-devised end system. However, these products are capable of emitting Class IV radiation. Extreme care must be exercised during their operation. Only persons familiar with the appropriate safety precautions should operate a laser product. Directly viewing the laser beam or exposure to specular reflections must be avoided. Serious injury may result if any part of the body is exposed to the beam. The eye is extremely sensitive to the infrared radiation and therefore, proper eyewear must be worn at all times. Use of optical instruments with these products may increase eye hazard. Always wear proper eye protection when operating.



DANGER

INVISIBLE LASER RADIATION
AVOID EYE OR SKIN EXPOSURE TO DIRECT OR SCATTERED RADIATION.

* Diode laser
5W & up, 750-1500nm
CLASS IV

WARNING
ELECTROSTATIC DISCHARGE SENSITIVE DEVICE
REQUIRING SPECIAL HANDLING



Rev A 01/06