

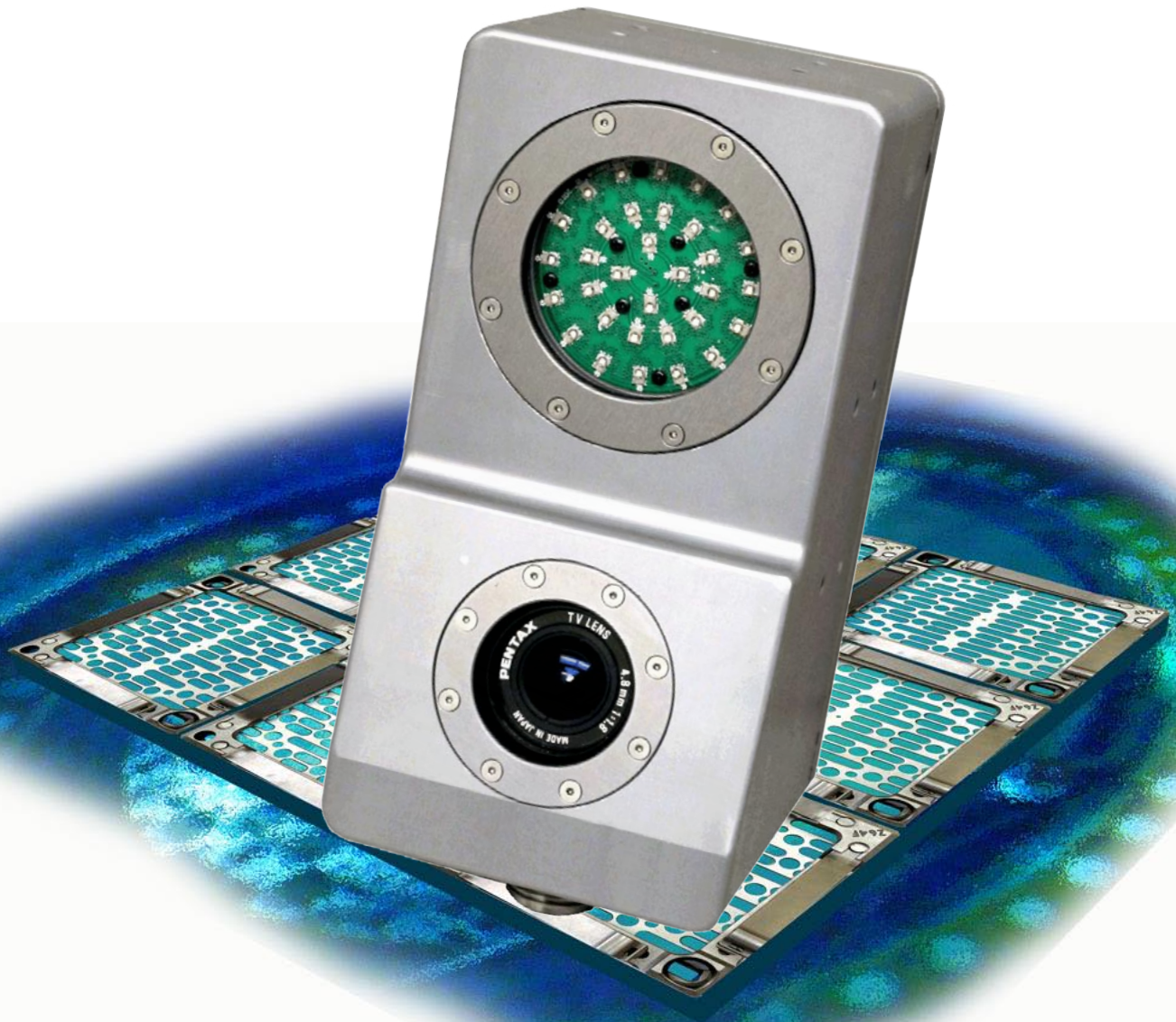

NM200E

Core Verification System



The revolutionary nuclear fuel mapping system

NEWTON

Fulfilling a Need of the Nuclear Power Industry

The NM200E Core Verification System is a revolutionary technology that enables nuclear plant operators to accurately measure the positions of all fuel assemblies in a PWR reactor at the end of an outage.

Developed by Newton Labs in partnership with a major U.S. nuclear utility, the NM200E produces a precise global map of fuel assembly s-hole positions, including any degree of misalignment or top nozzle rotation and compares them with the ideal positions established by plant engineers.

The accuracy of the NM200E is derived from sophisticated, Newton-developed software that compensate for the visually distorting thermal turbulence and use the core baffles as positional references.

In addition to accuracy, the NM200E features a considerably rapid mapping time of two hours or less. A major factor for the speed of the system, beyond software processing time, is an expanded field of view.

The NM200E system combines rugged, industrial-grade hardware and electronics into a design that can both tolerate radiation exposure and handle the rigors of deployment during reactor outages.

Construction and Materials:

- The 9 lb. (4 kg) mapping head is 6061T6 aluminum hard-anodized
- All fasteners and connectors are 316 Stainless Steel.
- Windows are made of high-strength fused silica
- O-rings and gaskets are Buna-N rubber and the cable jacket is LLDPE polyurethane.
- The mapping head is designed and built to tolerate radiation and has performed well in the presence of Gamma radiation levels of 5kR.
- The head is configured with alternate mounting points on most faces and is waterproof to a depth of 150 ft. (45.72 m).



NM200E Core Verification System

Components:

- The NM200E mapping head encloses a high-resolution video camera and a high-intensity LED ring array
- The console unit contains the camera control unit, a rack-mounted PC, flat panel screen and wireless keyboard with trackball
- The communications cable is a standard length of 150 ft. (45.72 m); lengths up to 300 ft. (91.44 m) may be special ordered
- Newton Labs core mapping software
- Components are housed in two, high impact airline-transportable luggage cases

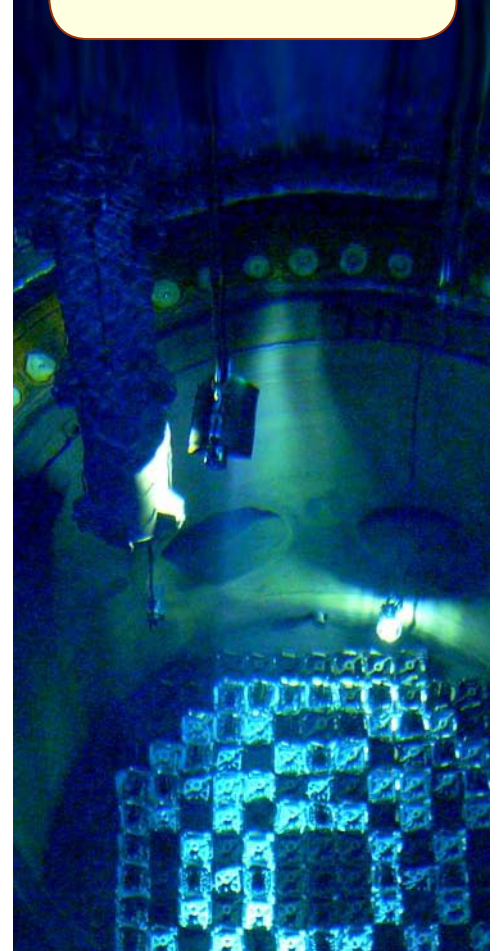

NEWTON

Core Verification Combining Accuracy and Speed

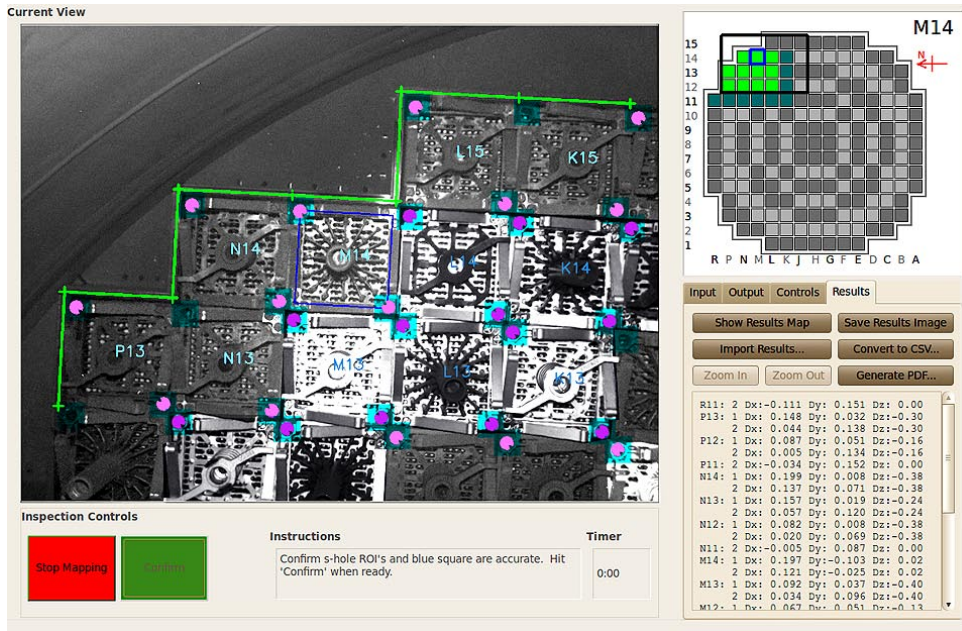

NM200E software overlays a graphic of identified s-hole locations atop the real-time image. The Core Map (upper right) displays the current mapping location and the in or out-of-tolerance status of each fuel assembly, compared to the ideal. In this example, the fuel assemblies in this scan area are all within tolerance

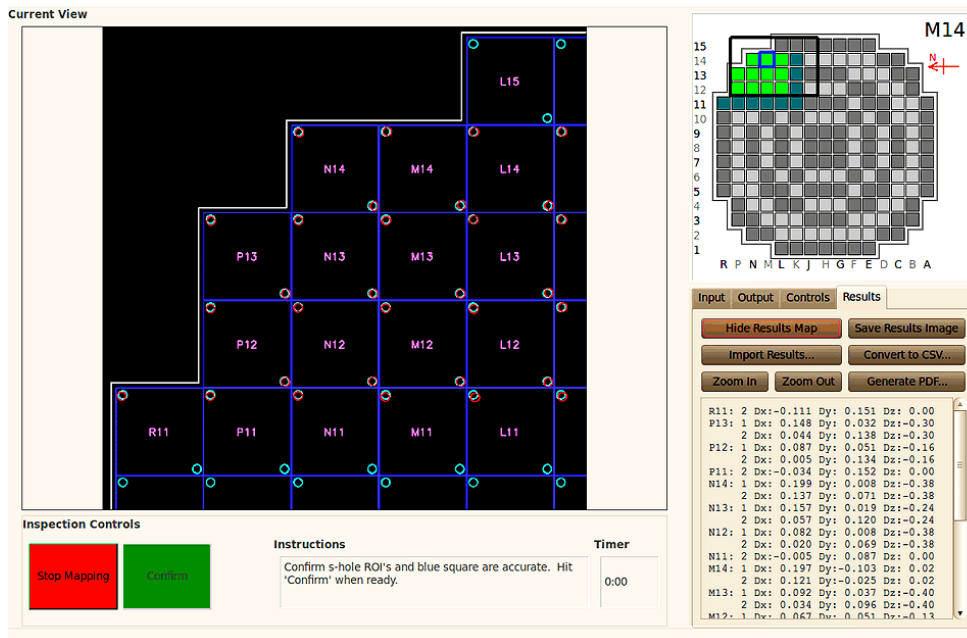

When selected, the Results Map (left) displays a graphical core representation identifying the location of found s-holes in relation to their ideal locations. The Results Tab (lower right) lists the deltas of all located s-holes.

The Core Mapping Sequence:

1. The camera, mounted in its false fuel assembly, is gripped by the refuel mast.
2. The bridge operator commands the bridge to a predefined location (i.e. fuel assembly N3) above the core.
3. The live video feed from the camera is displayed with a graphical alignment overlay generated from the fuel layout map. This reconfirms that the system is alive, ready and producing the anticipated images (clear, level, square, etc.).
4. The operator indicates the system can begin mapping into the user interface.
5. The NM200E takes a series of images at the first location that are processed using multiple techniques to accurately generate baffle and s-hole positions for all fuel assemblies in the field of view.
6. A global estimate of each s-hole location (in mm/inches) is generated, using the detected baffle position as a fixed reference point. The software identifies not only non-standard gaps, but also fuel assemblies that are rotated or shifted within the core.
7. The core map updates automatically, saving all data to redundant storage devices.
8. The camera head is moved to the next location, identified on the user interface, maintaining a partially overlapping field of view (FOV). The procedure is repeated.
9. The software combines and correlates the s-hole locations identified in all previous FOVs with the current FOV to account for changes in camera rotation and alignment, refining s-hole location estimates.
10. Upon reaching a baffle opposite the starting point, the camera is shifted laterally, maintaining some FOV overlap. The process is repeated in the reverse direction, continuing in a zig-zag pattern until all fuel assemblies have been seen by the system.
11. The core map display on screen visually indicates the final results of each mapped fuel assembly in one of three colors:

- Green - for within tolerance
- Yellow - for within tolerance, but greater than the specified gap
- Red - for out-of-tolerance

NEWTON

Designed and Built for the Rigors of PWR Outages

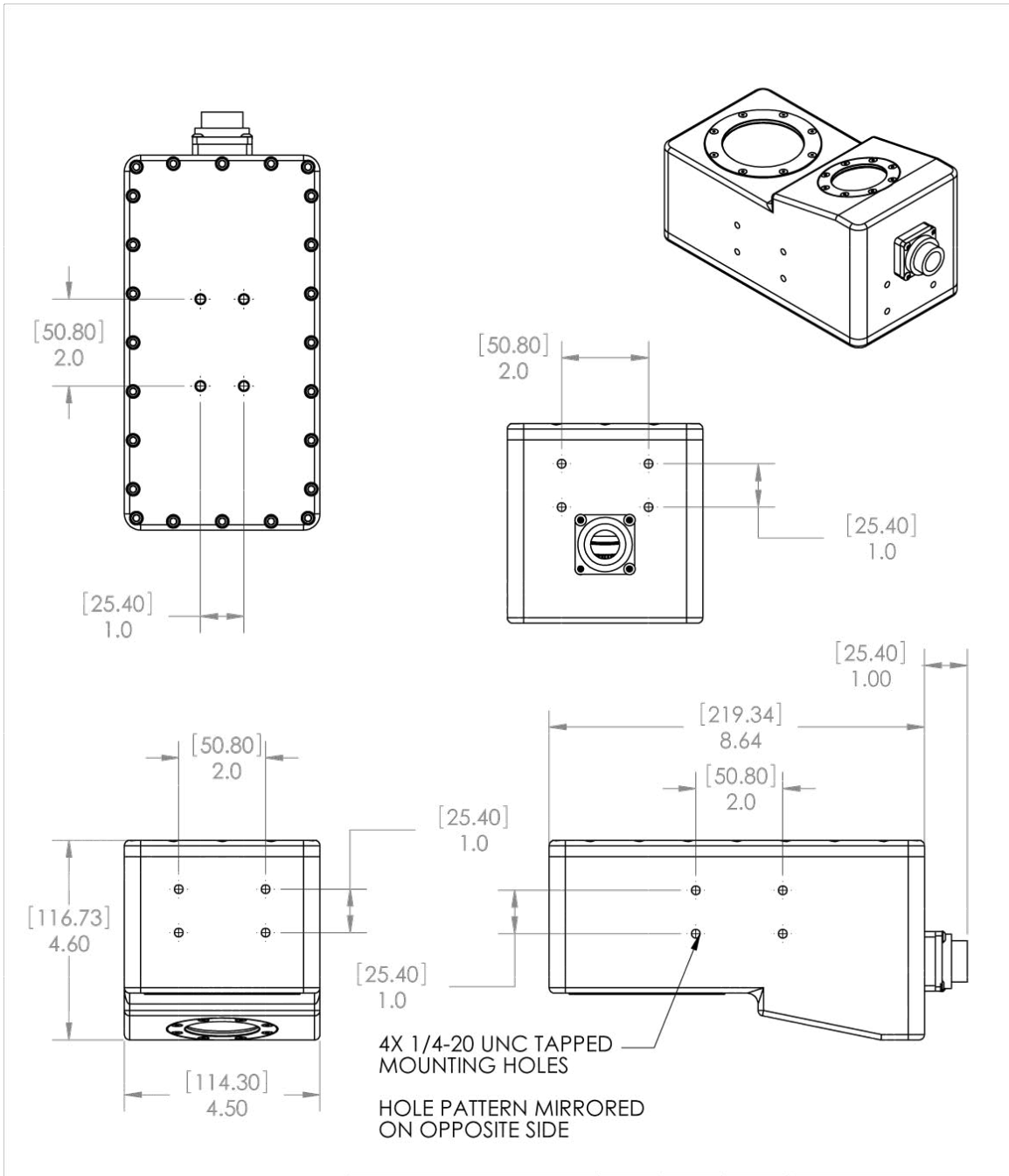

UNLESS OTHERWISE SPECIFIED DIMENSIONS ARE IN INCHES TOLERANCES: ANGULAR: ±3 ONE PLACE DECIMAL: ±.030 TWO PLACE DECIMAL: ±.010 THREE PLACE DECIMAL: ±.005 PROPRIETARY AND CONFIDENTIAL THE INFORMATION CONTAINED IN THIS DRAWING IS THE SOLE PROPERTY OF NEWTON RESEARCH LABS. ANY REPRODUCTION IN PART OR AS A WHOLE WITHOUT THE WRITTEN PERMISSION OF NEWTON RESEARCH LABS IS PROHIBITED.	DRAWN	N. LUTZHEISER	8/24/2011	441 SW 41st Street Renton, WA 98057 (425) 251-9600 www.newtonlabs.com
	CHECKED	G. ANDERSON	9/8/2011	
	APPR.			
	PROJECT:	NM-200E		
	DRAWING STATUS:	RELEASED		
COMMENTS:				NM-200E SIZE A DWG. NO. A100089 A-01 DO NOT SCALE DRAWING SHEET 2 OF 2



NM200E Technical Specifications

Item	Control Unit	Camera Head
Height	14.75 in. (374.65 mm)	4.5 in. (114.30 mm)
Width	26.75 in. (679.45 mm)	4.60 in. (116.73 mm)
Length	27.50 in. (698.5 mm)	8.64 in. (219.34 mm)
Weight (in air)	84.5 lbs. (38.3 kg)	9 lbs. (4 kg)
Weight (in water)	---	2 lbs. (1 k) (plus cable weight)
Construction	Metal electronics rack suspended on eight shock absorbers within a molded, high-impact, airline-transportable case	Machined from solid billet of 6061T6 aluminum stock
Cable	LLDPE polyurethane jacket, gel filled - 150 ft. (45.72 m) (other lengths available)	---
Cable weight - 150 ft. (in air)	23.6 lbs. (10.7 kg)	---
Video camera	---	High Resolution Monochrome
LED ring array	---	4,800 lumens
Fittings & retainers	---	300 series stainless steel
Windows	---	Fused silica or optical glass
Mounting attachments	---	Four grouped 1/4-20 UNC threaded mounting holes on four sides of case (Metric threads available)
Operating system	Ubuntu Linux 11.04	---
Output ports	Ethernet, USB, DVI, VGA & HDMI	---
Operating temperature	40° to 110° F (5° to 43° C)	86° to 95° F (30° to 35° C) in reactor 100% duty cycle
Storage temperature	0° to 125° F (-18° to 52° C)	0° to 160° F (- 18° to 71° C)
Power input voltage/current	100 to 240 VAC 50 to 60 cycle	Powered by control unit
Data storage	Internal solid state & USB stick data	---
Output formats	XML, CSV, PNG & PDF	---
Watertight depth rating	---	150 ft. (45.72 m)

Comparison to Video Micrometer Procedure

- The NM200E offers substantial advantages over the legacy video micrometer process in terms of accuracy and mapping time.
- The video micrometer method merely gauges the relative nozzle gap variations, limiting an operator to only being able to infer the position of s-holes.
- The accuracy of a video micrometer scan is highly dependent on operator experience and camera orientation, processes that are handled automatically and consistently by the NM200E.
- The video micrometer field of vision is no more than one and a half fuel nozzles wide, resulting in a considerably longer mapping time, compared to the NM200E, which registers an area of three by four nozzles and can completely map a core in less than two hours.

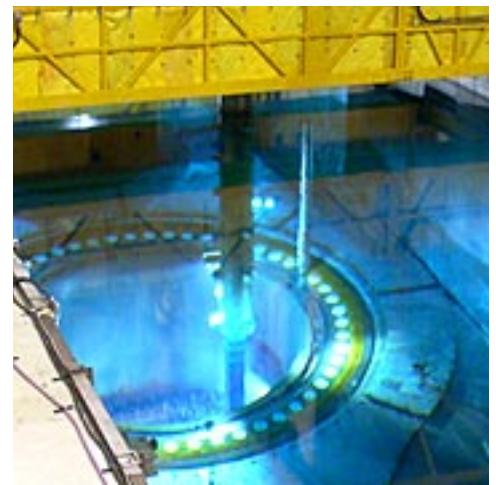

NEWTON

Information on Newton Labs

Newton Labs is a privately held developer and manufacturer of machine vision, robotics and optical automation. A spin-out from the Massachusetts Institute of Technology (MIT), the company has for more than 18 years developed and marketed high performance, computer-driven automation for industrial processes. Newton's products are designed to allow the quality, efficiency and cost effectiveness of computer technology to replace the human element in virtually every industry. Newton Labs has deployed more than 20,000 machine vision, robotic and automation systems worldwide.



Offices and manufacturing facilities of Newton Labs - Renton, Washington, USA

A Related Nuclear Industry Product from Newton Labs

An industry "sister product" is the **NM200UW Nuclear Underwater Laser Scanner**, a landmark technology developed by Newton Labs in partnership with a major U.S. nuclear utility.

The scanner output is a point cloud so detailed, that when utilized with industry standard, 3-D software, a fully measurable CAD model can be generated.

The capability of the NM200UW to provide precise, reliable and efficient dimensioning of as-built features, as well as to track cycle-to-cycle degradation, is important to nuclear utility operators, who until now have relied heavily on indirect, inexact measurement techniques.



NM200UW Nuclear Underwater Laser Scanner

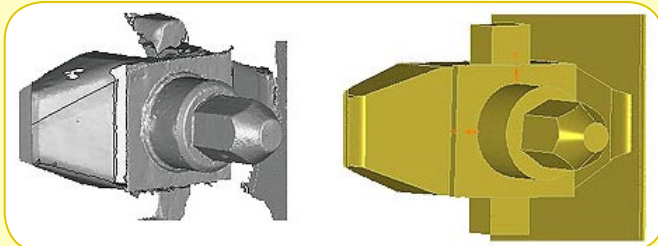

Left: The point cloud output of an underwater retaining bolt scanned by a NM200UW
Right: The measurable CAD file rendering of the same scanned bolt.

For more information about this product, contact Newton Labs:

lasersales@newtonlabs.com or call 425-251-9600



NEWTON

Revised 012612