

Redefining Measurement

Use Case: Quantum Optics

Towards a Quantum Internet



Customer: ICFO Institute of Photonic Sciences

Research Field: Quantum Optics

Country: Spain

Customer Need



In heralded-entanglement experiments, ICFO needed to collect photons as efficiently with as little background noise as possible

Solution



ID281 SNSPDs with > 80% Quantum Efficiency and < 14 Hz Dark Count Rate at 1450 nm

Results



Successful entanglement of remote quantum memories and entanglement between a telecom-wavelength photon and an on-demand multimode quantum memory

Context

The ability to distribute entanglement across a quantum network is of paramount importance in a future-proof quantum internet. In building quantum communication channels, it would help to extend the channels' range through quantum repeater technology. Later, it will allow for distributed quantum computing, sharing arbitrary quantum states across a range of remote nodes, giving access to a richer repertoire of quantum computing protocols.

Three key capabilities are needed for this kind of remote entanglement distribution:

1. Generating quantum-entangled states,
2. Storing quantum states for controllable lengths of time with high fidelity, and
3. Interconverting quantum states between flying qubits (typically telecom-wavelength photons) and stationary qubits (typically massive particles).

Samuele Grandi, Dario Lago-Rivera, Jelena V. Rakonjac and Alessandro Seri, in the group of Hugues de Riedmatten at ICFO in Barcelona, set themselves the task of marrying these three capabilities together, and have recently demonstrated just that, in [‘Telecom-heralded entanglement between multimode solid-state quantum memories’ \(Nature 2021\)](#) [1] and [‘Entanglement between a telecom photon and an on-demand multimode solid-state quantum memory’ \(arXiv 2021\)](#) [2].

Customer Need

The work at ICFO centres around the heralded quantum entanglement of photon pairs, generated through spontaneous parametric down conversion (SPDC) and the subsequent storage of the entangled photons in Quantum Memories with atomic frequency comb (AFC) and spin-wave (SW) storage.

In the ICFO group’s entanglement source, a pair of strongly correlated photons are generated in a frequency-mixing process such as SPDC. Sending each photon of the pair through different arms of the experiment, the arrival of the ‘idler’ photon at one detector tells the user when and where they can find a single ‘signal’ photon. In this way, observing heralded single photons requires a coincidence measurement of two photons.

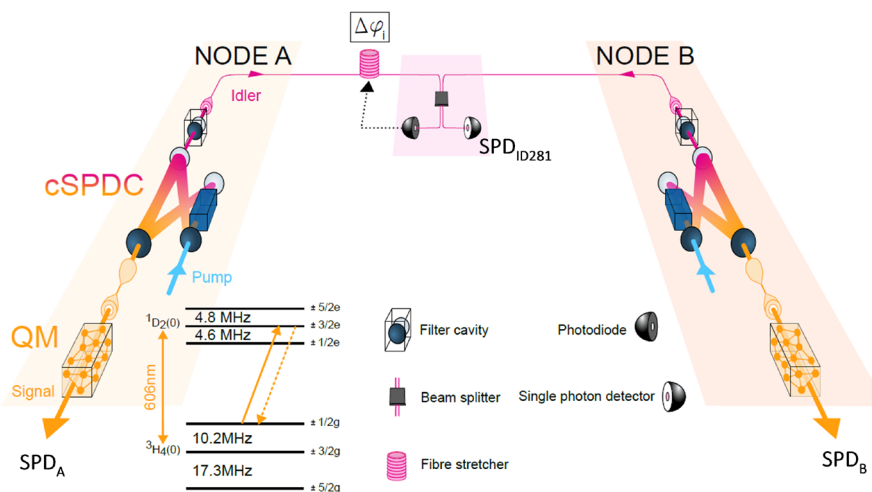

Figure 1: Configuration of the two nodes of the experiment, taken from D. Lago-Rivera, S. Grandi et al. (2021) [1]. Each node has its own SPDC source and quantum memory. The detection of a 1436 nm idler photon at the central ID281 SNSPD indicates the presence of a single 606 nm signal photon in the two nodes, and the subsequent entanglement of the two quantum memories.

The ICFO group’s experiments expand on this: two photon pair sources are used to herald entanglement between two remote quantum nodes (or between one node and one signal photon). In their arrangement (see Figure 1), they only have one signal photon in the system at a time. However, to be sure they’re not experiencing unwanted two-photon events, they need to measure the rate of triple-coincidences between detectors SPD_{ID281}, SPD_A and SPD_B in their experiment. Expanding their experiment into entanglement swapping, they may later want to measure quadruple-photon coincidences.

Solution

Performing these coincidence measurements requires time-correlated single-photon counting (TCSPC). Since the photon detection statistics in TCSPC follow a Poissonian distribution, detector efficiency and the detector dark count rate were of primary importance. An improvement in the efficiency would see a corresponding decrease in the time needed to build equivalent statistics by between a power of two and three. A decrease in the dark count rate would have a similar improvement on the quality of the measured statistics.

As such, ID Quantique provided ICFO with a set of ID281 superconducting nanowire single-photon detectors (SNSPDs), SPD_{ID281} in the experimental setup in Figure 1. These detectors have greater than 80% efficiency at the wavelength of interest (c. 1450 nm for the idler photon detection) and < 14 Hz dark count rate.

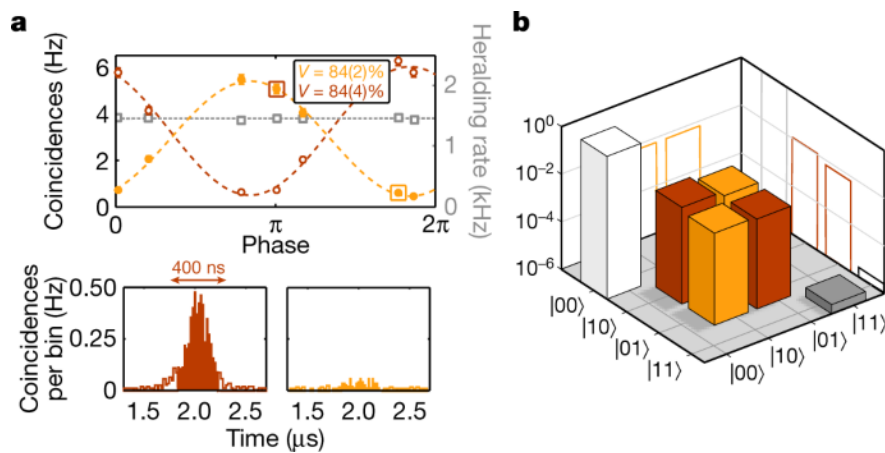

Figure 2: Measurements of the recombined node A and node B signal photons, after a storage time of $2 \mu\text{s}$, taken from D. Lago-Rivera, S. Grandi et al. (2021) [1]. Coincidences are measured between detection events at the ID281 SNSPD and one of two detectors after the combined node A & B signal.

Results

ICFO demonstrated successful entanglement of remote quantum memories [1] and, for the first time, entanglement between a telecom-wavelength photon and an on-demand multimode solid-state quantum memory [2], all in a practical timeframe, laying the groundwork for a future quantum repeater.

“

The high efficiency and low dark counts of the new ID281 detectors reflected directly into an improved signal-to-noise ratio and in dramatic reduction in the required experimental time, allowing for short and consistent measurements and relaxing the need for long-term stabilisation.

Samuele Grandi
ICFO Institute of Photonic Sciences

They achieved matter-matter entanglement between two quantum memories, with 2 μs storage times at a heralded entanglement rate of 1.43 kHz. This marks a 40-fold improvement on the current record between quantum memories. Even at longer storage times, up to 25 μs , they saw concurrences more than five standard deviations above zero, indicating continued entanglement, which would allow entanglement distribution across 5 km of optical fibre.

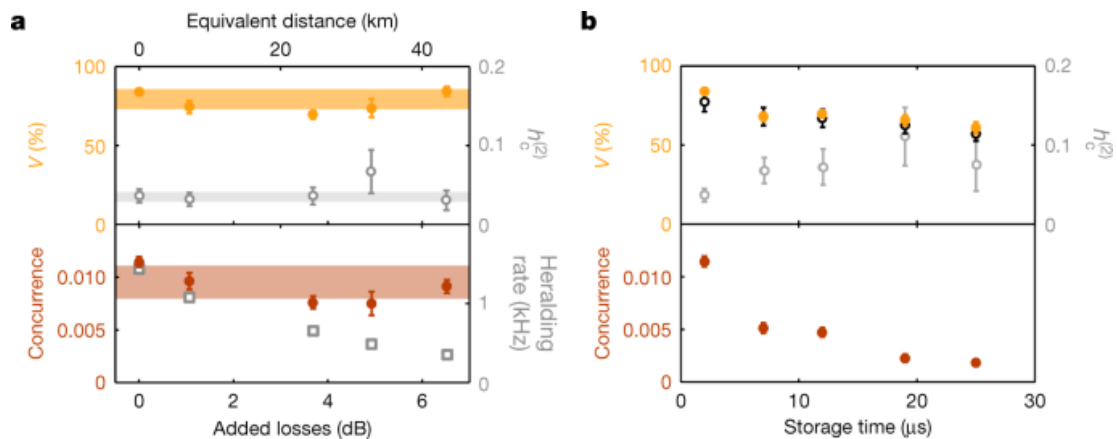

Figure 3: Measurement of the overall quantum state's visibility and concurrence for (a) artificially added channel losses, simulating extended distances, and (b) increases in the QM storage time up to 25 μs (taken from D. Lago-Rivera, S. Grandi et al. (2021) [1]).

This research demonstrates some of the key building blocks needed to build a scalable quantum repeater. The work represents significant progress in the infrastructure needed to communicate between dissimilar quantum states separated by tens of kilometres, and from there, one can perform all kinds of operations in a metropolitan-scale distributed quantum computer. The advances made here are an important step towards a Quantum Internet.



- [1] 'Telecom-heralded entanglement between multimode solid-state quantum memories', D. Lago-Rivera, S. Grandi et al., 2021, [Nature 594, 37–40 \(2021\)](#)
- [2] 'Entanglement between a telecom photon and an on-demand multimode solid-state quantum memory', J. V. Rakonjac, D. Lago-Rivera et al., 2021, [arXiv:2106.05079](#)

Disclaimer: The information and specification set forth in this document are subject to change at any time by ID Quantique without prior notice.
 Copyright© 2021 ID Quantique SA - All rights reserved - ICFO_Towards a Quantum Internet