



Gooch & Housego



Single Fuse Coupler 1x3, 3x3, 1x4, 4x4

The Single Fuse Coupler provides optical splitting and combining for >2 ports. A single low loss fusion takes place to produce 1x3, 3x3, 1x4 and 4x4 couplers in a single cylindrical package.

Standard versions of these components are available optimised for 980, 1310, 1480, 1550 or 1585nm wavelengths. These may be used in a wide variety of applications including optical network expansion.

Single Fuse Couplers, by virtue of their phase properties, are also ideal for use in fibre gyros. Versions are available with ultra-compact housings and $\varnothing 80\mu\text{m}$ cladding fibre pigtails, directly compatible with gyro sensing loops. Low loss ensures optimal gyro sensitivity.

These gyro-optimised Single Fuse Couplers are available on a custom basis. Please contact us for a specification tailored to your requirements.

Key Features:

- Single low loss fusion
- 1x3, 3x3, 1x4, 4x4
- Standard product for network expansion
- $\varnothing 80\mu\text{m}$ cladding fibre capability
- Custom designs for gyro applications

Applications:

- Optical network expansion
- Fibre gyros
- Sensors
- Research

As part of our policy of continuous product improvement we reserve the right to change specifications at any time
PEC 0115 Issue 3



光技術をサポートする
株式会社オプトサイエンス
<http://www.optoscience.com>

東京本社 〒160-0014 東京都新宿区内藤町1番地 内藤町ビルディング
TEL: 03 (3356) 1064 FAX: 03 (3356) 3466 E-mail: info@optoscience.com
大阪支店 〒532-0011 大阪市淀川区西中島7-7-2 新大阪ビル西館
TEL: 06 (6305) 2064 FAX: 06 (6305) 1030 E-mail: osk@optoscience.com
名古屋営業所 〒450-0002 名古屋市中村区名駅2-37-21 東海ソフトビル
TEL: 052 (569) 6064 FAX: 052 (569) 8064 E-mail: ngo@optoscience.com

Optical Specifications₁

Parameter	Specification								Unit
Operating Wavelength	980, 1310, 1480, 1550 or 1585nm								nm
Port Configuration	1x3		3x3		1x4		4x4		
Coupling Ratio	33/33/33		33/33/33		25/25/25/25		25/25/25/25		
Grade	A	B	A	B	A	B	A	B	%
Maximum Insertion Loss ₂	5.7	6.2	6.2	6.5	7.0	7.8	8.0	8.6	dB
Return Loss/Directivity	50								dB
Pigtail Tensile Load	5								N
Optical Power Handling	4								W
Operating Temperature ₃	-40 to +75								°C
Storage Temperature	-40 to +85								°C
Fibre Type	Corning SMF-28 ₄ or 980nm fibre ₅								

1. All specifications are preliminary.
2. Insertion loss (not including PDL, TDL or any connector losses).
3. For connectorised component, operating temperature range is -5 to +75°C.
4. Custom designs using Ø80µm fibre for gyro applications are available. Please contact the sales office for further information.
5. For 980nm component.

Housing Option

Housing Code	Description	Dimensions (mm)		Pigtail
3	Regular	1x3, 3x3	3.0 (Ø) x 55 (L)	Primary-coated fibre
		1x4, 4x4	3.0 (Ø) x 71 (L)	

Ordering Code Information

Sample: FFC-CF33AN110 (1550nm, 33%, regular, 1x3, A grade, SMF-28 fibre, 1m pigtail, no connector)

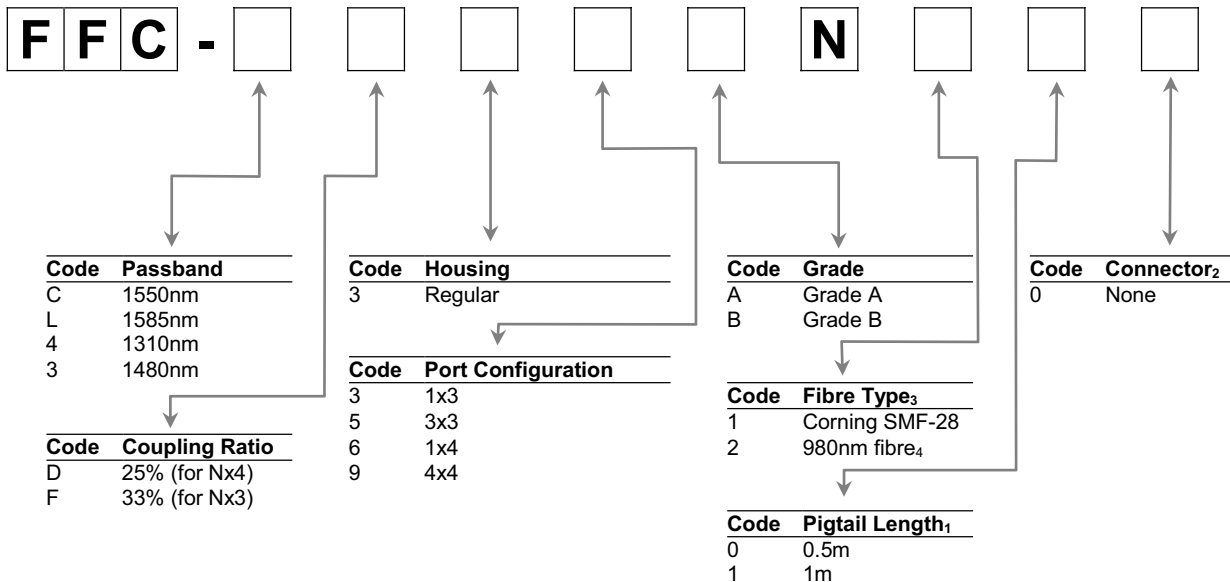

1. Minimum pigtail length. Further pigtail lengths available on request. Where connectorised, pigtail length is to connector end face.
2. For connectorisation of this component please contact the sales office.
3. Custom designs using Ø80µm fibre for gyro applications are available. Please contact the sales office for further information.
4. For 980nm components only.

As part of our policy of continuous product improvement we reserve the right to change specifications at any time
PEC 0115 Issue 3

