



# Eye-Safe Wavelength and NIR CS-Mounted Bars

## Applications

- Laser pumping: Solid state lasers, Fiber lasers
- Medical: Dermatology, Aesthetic
- Printing: Computer to plate, flexography
- Materials Processing: Plastic welding
- Defense: Illumination

## Features

- Up to 50 W from a conduction cooled package
- 795 nm, 808 nm, 940 nm, 1470 nm, and 1532 nm
- Industry leading power per emitter
- Fast and slow axis collimating lens available



## Benefits

- Highest performance from solid state and fiber lasers due to industry leading brightness and power
- Increased throughput for printing applications from industry leading power and brightness
- Reduced system cost by reducing the number of bars
- Longer working distance, simpler optical design

CONDUCTION COOLED LASER BARS									
PART NO.	4101-A	4101-B	4201-A	4201-B	4301-A	4301-B	4401-A	4401-B	4501
Center Wavelength	795 nm	795 nm	808 nm	808 nm	940 nm	940 nm	1470 nm	1470 nm	1532 nm
Wavelength Tolerance	±3 nm	±3 nm	±3 nm	±3 nm	±3 nm	±3 nm	±5 nm	±5 nm	±5 nm
Spectral Width (FWHM)	<3 nm	<3 nm	<3 nm	<3 nm	<3 nm	<3 nm	<12 nm	<12 nm	<12 nm
Output Power	40 W	50 W	40 W	50 W	40 W	50 W	20 W	25 W	20 W
Operating Current	<47 A	<63 A	<47 A	<63 A	<50 A	<70 A	<55 A	<75 A	<60 A
Operating Voltage	<1.85 V	<1.85 V	<1.85 V	<1.85 V	<1.6 V	<1.6 V	<1.5 V	<1.5 V	<1.5 V
Threshold Current	<10 A	<17.5 A	<10 A	<15 A	<12 A	<18 A	<8 A	<9 A	<8 A
Slope Efficiency	>1.05 W/A	>1.05 W/A	>1.05 W/A	>1.05 W/A	>0.95 W/A	>0.95 W/A	>0.4 W/A	>0.4 W/A	>0.4 W/A
Conversion Efficiency	>45 %	>45 %	>45 %	>45 %	>50 %	>50 %	>35 %	>30 %	>30 %
dλ/dT	0.3 nm/°C	0.3 nm/°C	0.3 nm/°C	0.3 nm/°C	0.3 nm/°C	0.3 nm/°C	0.35 nm/°C	0.35 nm/°C	0.35 nm/°C
Slow Axis Divergence (FWHM)	<10 deg.	<10 deg.	<10 deg.	<10 deg.	<10 deg.	<10 deg.	<12 deg.	<12 deg.	<12 deg.
Fast Axis Divergence (FWHM)	<40 deg.	<40 deg.	<40 deg.	<40 deg.	<35 deg.	<35 deg.	<38 deg.	<38 deg.	<38 deg.
Number of Emitters	19	25	19	25	19	25	19	25	19
Emitter Width	150 micron	200 micron	150 micron	200 micron	150 micron	200 micron	100 micron	100 micron	100 micron
Emitter Spacing	500 micron	400 micron	500 micron	400 micron	500 micron	400 micron	500 micron	400 micron	500 micron
Fill Factor	30 %	50 %	30 %	50 %	30 %	50 %	20 %	25 %	20 %
Polarization	TE	TE	TE	TE	TE	TE	TE	TE	TE
Bar Emission Width	9.7 mm	10.1 mm	9.7 mm	10.1 mm	9.7 mm	10.1 mm	9.5 mm	10.0 mm	9.5 mm

Operating conditions at 20 degrees Celsius unless otherwise noted



光技術をサポートする  
**株式会社オプトサイエンス**  
<http://www.optoscience.com>

東京本社 〒160-0014 東京都新宿区内藤町1番地 内藤町ビルディング  
 TEL: 03 (3356) 1064 FAX: 03 (3356) 3466 E-mail: info@optoscience.com  
 大阪支店 〒532-0011 大阪市淀川区西中島7-7-2 新大阪ビル西館  
 TEL: 06 (6305) 2064 FAX: 06 (6305) 1030 E-mail: osk@optoscience.com  
 名古屋営業所 〒450-0002 名古屋市中村区名駅2-37-21 東海ソフトビル  
 TEL: 052 (569) 6064 FAX: 052 (569) 8064 E-mail: ngo@optoscience.com

**BRIGHTNESS and POWER**  
 Breaking Performance Barriers through Semiconductor Laser Innovation

QPC Lasers, Inc.

15632 Roxford Street • Sylmar, CA 91342 • Phone: +1 (818) 986-0000 • Fax: +1 (818) 698-0428  
[www.QPClasers.com](http://www.QPClasers.com) • email: info@QPClasers.com





# Eye-Safe Wavelength and NIR CS-Mounted Bars

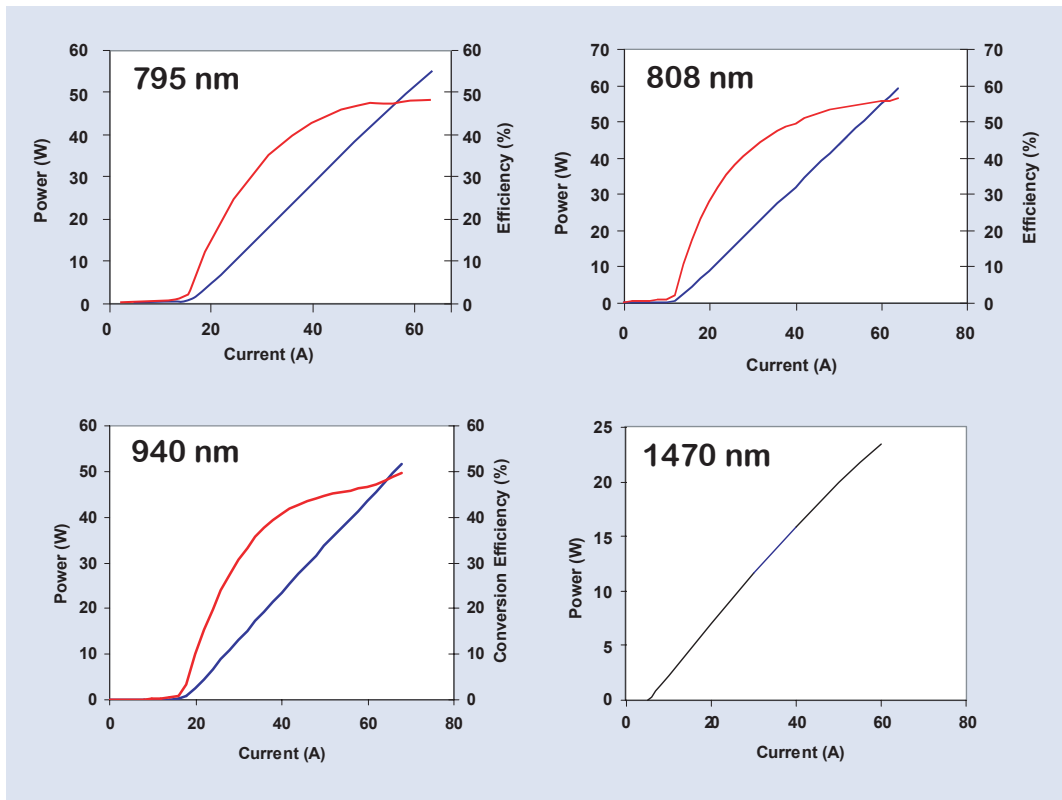
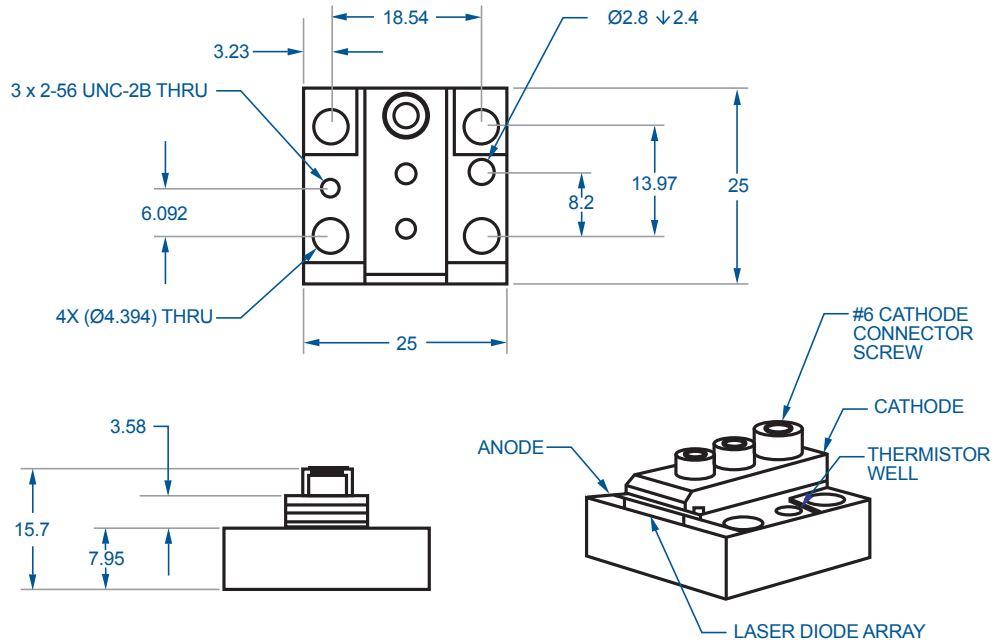

**BRIGHTNESS and POWER**  
**Breaking Performance Barriers through Semiconductor Laser Innovation**

QPC Lasers, Inc.

15632 Roxford Street • Sylmar, CA 91342 • Phone: +1 (818) 986-0000 • Fax: +1 (818) 698-0428  
www.QPClasers.com • email: info@QPClasers.com