

# Tunable Optical Filters

## Standard Tunable Optical Filters

A Tunable Optical Filter consists of multiple liquid crystal variable retarders and polarizers protected in a temperature-controlled housing. Temperature control is important since the birefringence of the liquid crystal variable retarders is a function of temperature as well as voltage. Each liquid crystal cell that goes into the Tunable Filter is made to be highly uniform in retardance using our proprietary manufacturing processes. This produces the best uniformity of transmission wavelength across the clear aperture.

VersaLight polarizers are generally used with remarkably low losses, producing a final filter with very high transmission. Additionally, the polarizers have very wide fields of view and can accommodate much higher flux than standard dichroic polarizers.

The electronics controller supplies the appropriate voltages to each of the liquid crystal variable retarders and maintains the temperature of the housing. All of the calibration data for each variable retarder is stored into memory on the electronics controller. When commands are issued to the controller via USB and serial port; the calibration data are accessed and new voltages to each of the variable retarders are initiated simultaneously.

To issue commands via USB or serial port from a computer,

## Key Benefits

- Broad tuning range
- Uniform clear aperture
- High peak transmission
- Multiple control interface options
- Replace thousands of interference filters
- Stable performance over wide ambient temperature range

FilterDRIVE software is provided. This software allows a user to input a desired wavelength value using a keyboard or mouse. Firmware serial commands are provided in the user's manual for those wishing to control tunable filters using their own custom software.

Our filter housings are designed to be easy to integrate into existing optical systems. Mounting points are standard 8/32 threaded; and both apertures come with c-mount threaded aluminum mounts for easy attachment of optical components.

Below are sample transmission curves for our standard products, specifications for our standard tunable filters are shown at the end of this section; we also build custom filters.

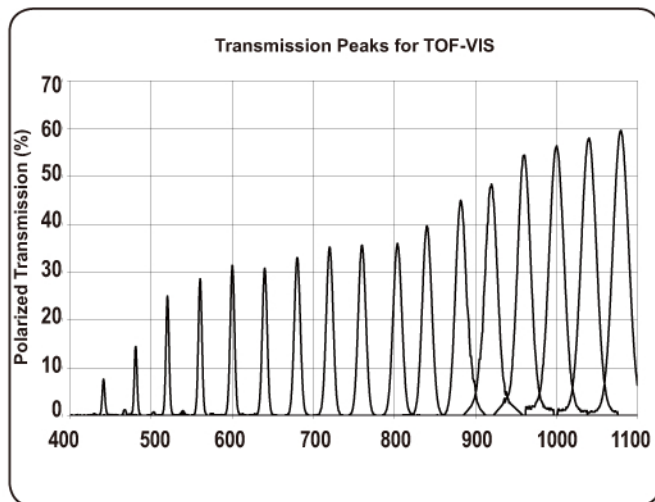

Fig. 7-2 Typical Filter curves for the TOF-VIS

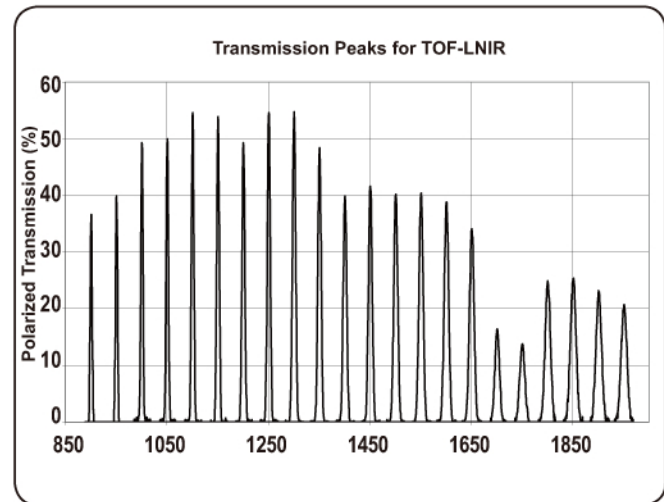
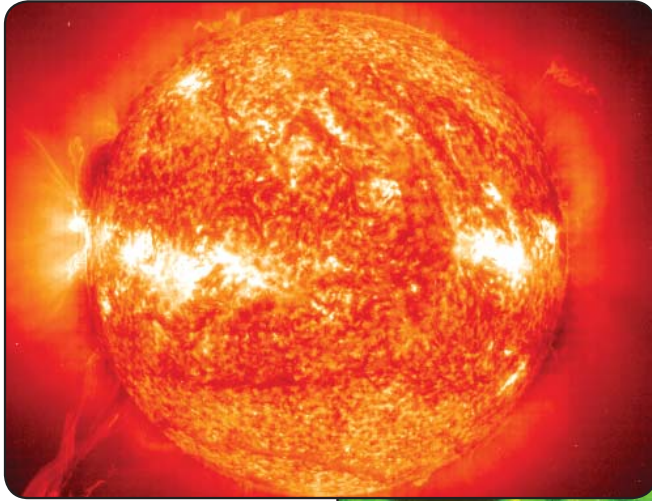

Fig. 7-3 Typical Filter curves for the TOF-LNIR



# Tunable Optical Filters



Solar Astronomy

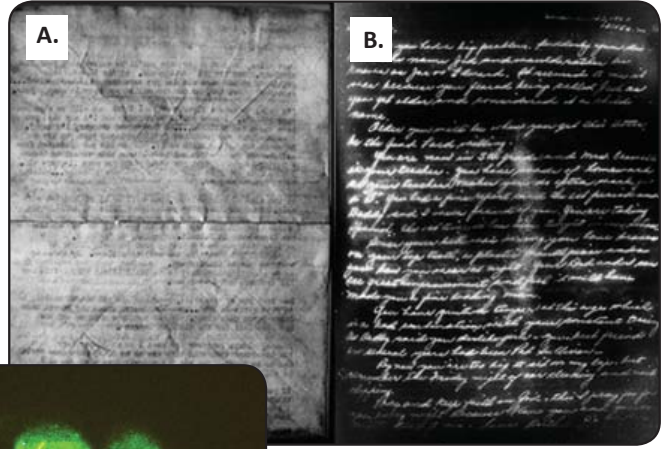

Document Verification:  
A. Ordinary Illumination  
B. Through Filter

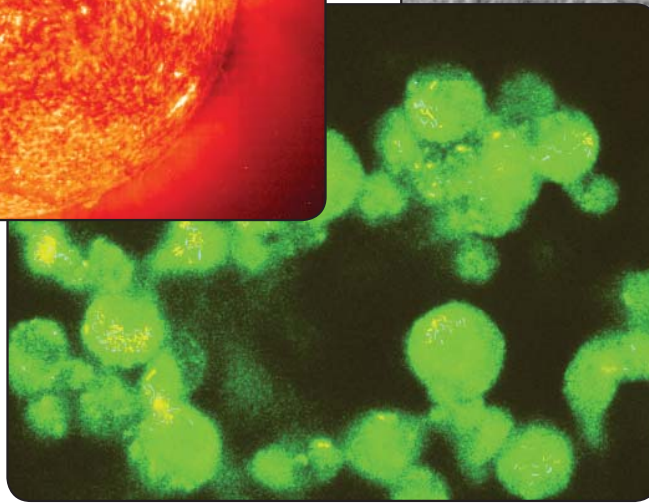

Fluorescence Microscopy

## Custom Tunable Optical Filters

Meadowlark Optics excels at providing customized Tunable Filters for all kinds of applications. Whether you are doing astronomical imaging, microscopy, or remote imaging, we can find a solution that meets your needs. Since all components are made in-house, a wide range of customization is possible. Whether you would like a larger clear aperture, a narrower pass band, a wider field of view, a variable pass band, or more, we can do it. When deciding on specifications for a custom filter, it is important to remember that not all specs can be chosen completely independently. The most important spec to consider is the finesse,  $f$ , which is defined as is the ratio between the free spectral range (FSR) of the filter and the full width at half maximum (FWHM) of the pass band. Higher finesses are achieved by adding more stages and thus more optics, which leads to a more expensive filter and also to lower peak transmission.

Peak transmission is another important specification. This is defined as the maximum transmission of the pass band curve. Additionally peak transmission is generally reported for light that is polarized along the transmission axis of the first polarizer in the Tunable Filter. If unpolarized light is incident on the filter then the peak transmission will be half of the polarized peak transmission. The peak transmission is a function of the center wavelength of the pass band as well as the number of optics in the Tunable Filter. This means that the peak transmission is highly dependent on the optical finesse, since higher finesses have more optics and hence more absorptive elements.

Other specifications include field of view, which defines the applicable half-cone angle from the optical axis for which the filter performance is guaranteed. Thus the rays entering the Tunable Filter should be kept less than this angle. If this is not possible, the main result will be a decrease in the out-of-band rejection. Out-of-band rejection is the measure of how much light, which is not within the pass band, gets through the filter; it is usually desirable to have the out-of-band rejection as high as possible. Other specifications including the tuning accuracy of the peak transmission can be optimized in Custom Filters.

Meadowlark Optics has several proprietary and patent-pending designs for Tunable Filters. If you are interested in a Custom Tunable Filter with a very wide field-of-view, a variable FWHM (i.e. several different FWHMs possible at a particular wavelength) or any important specifications, please call us to discuss custom filter requirements.

### Applications:

- Remote Sensing
- Solar Astronomy
- Document Verification
- Hyperspectral Imaging
- Fluorescence Microscopy
- Biological/Chemical Imaging
- Pharmacological Development
- Chromographic Analysis
- Filter wheel replacement

# Tunable Optical Filters

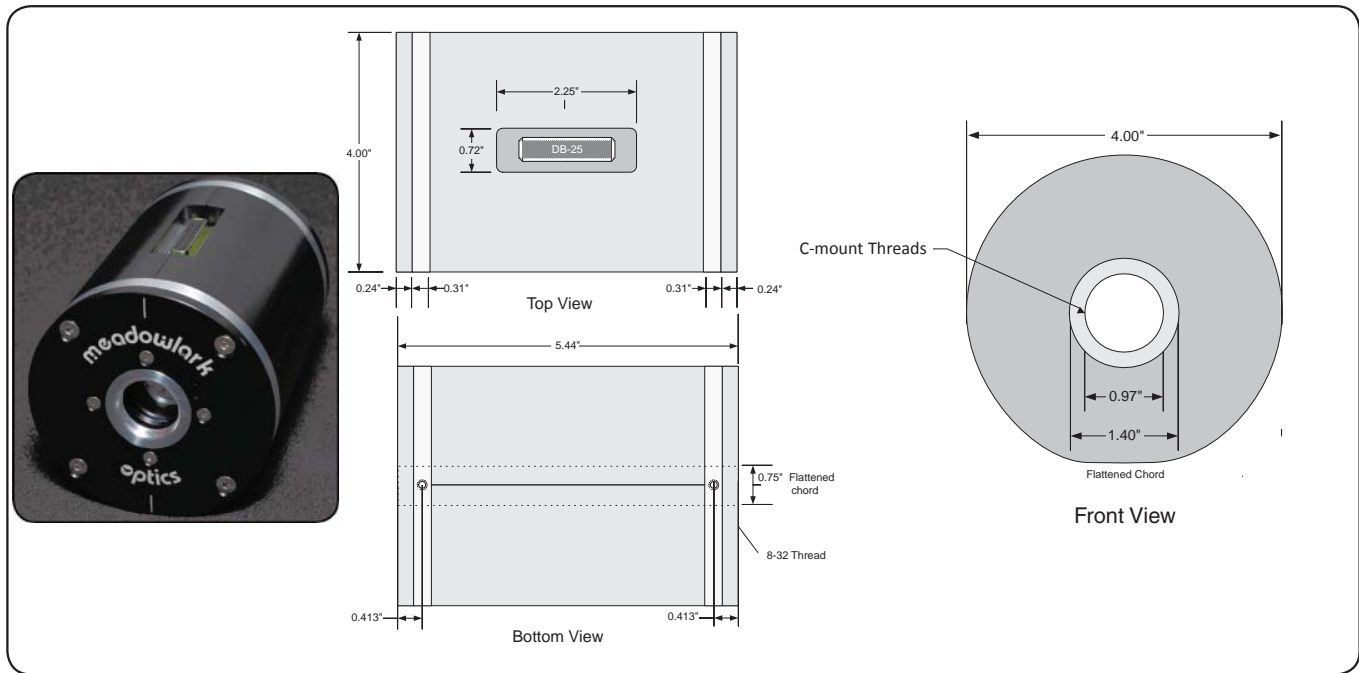

Fig 7-4 Tunable Optical Filter Mechanical Drawing

SPECIFICATIONS AND ORDERING INFORMATION				
Part Number	Standard Filters		Custom Filters	
	TOF-VIS	TOF-NIR	Design Space (requires specification tradeoffs)	TOF-1075 (custom example)
Wavelength Range	420-1100 nm	850-1976 nm	350-2500 nm	1071-1078 nm
Clear Aperture Diameter	20 mm	20 mm	5-100 mm	20 mm
Full Width at Half Max (FWHM) (increases with $\lambda$ )	5 nm @ 550 nm	6 nm @ 1300 nm	0.1 to 100 nm	0.2 nm @ 1075 nm
Polarized Peak Transmission	5-60%	10-55%	80% max (based on design)	56%
Tuning Resolution	0.1 nm	0.1 nm	~ 2% FWHM	0.001 nm
Tuning Accuracy	FWHM/10	FWHM/10	Based on design	FWHM/10
Field of View (Half Cone Angle)	6°	3°	Based on design	3°
Switching Speed	< 100 ms	< 100 ms	10 to 500 ms	< 100 ms
Temperature Range	10°C - 35°C	10°C - 35°C	10°C - 35°C	0°C - 35°C
Out-of-Band Blocking	> OD2			
Power Requirements	90-264 V ac 47- 63 Hz 2A			
Controller Dimensions (L x W x H)	9.50 x 6.25 x 1.50 inches			
Controller Weight	2 lbs.			
Minimum Systems Requirements	<ul style="list-style-type: none"> <li>• PC with Pentium II class processor</li> <li>• 32 MB RAM</li> <li>• CD ROM drive</li> <li>• 20 MB hard drive space</li> <li>• USB or RS232 COM Port</li> <li>• Windows™ 98/ME/2000/XP/Vista</li> <li>• Use of LabVIEW Instrument Library requires LabVIEW version 6.1 or higher</li> </ul>			