

# Pulsed Laser Diode Module LC-Series



## DESCRIPTION

The LC-series of pulsed laser diode modules offer all of the features needed to safely drive pulsed lasers of different powers, in a compact housing. The modules are easy to handle and require only a +12 VDC supply and a trigger signal. External devices, such as trigger interfaces, are not necessary. These modules make the operation of pulsed lasers as straightforward as their cw counterparts.

For most applications it is only necessary to drive the laser with constant power and pulse length. These parameters will be preset from production on customer's requirement.



The metal housing is fully nickel-plated, in order to reduce EMI emissions from the module, and to protect the module from any external EMI.

Custom designed modules are available on request.

## FEATURES

- Wavelength: 905 nm / 1550 nm
- Optical Peak Power: 3 W - 200 W
- Integrated pulsed laser diode
- Peak power and pulse length preset to customer requirement
- Short rise and fall times
- Compact housing
- Complete unit – no additional equipment needed
- Straightforward interfacing (standard drive voltages, TTL & CMOS trigger)
- Excellent temperature stability

## APPLICATIONS

- Ranging
- Surveying equipment
- Weapons simulation
- Laser radar / LIDAR
- Security barrier
- Ceilometer
- Medical
- Illumination
- Optical trigger



## SPECIFICATIONS FOR 905 nm PLD-MODULE

Part Number	LC9-XX-YYY-1S03-S10	LC9-XX-YYY-1S3J03-S10	Dim.
Wavelength	905	905	nm
Optical Peak Power (NA>0.5)	3 – 7*	10 – 25*	W
Pulse Length	30 – 150*	30 – 150*	ns
Trigger Input	TTL ↑	TTL ↑	-
Max. Duty Cycle	0.1	0.1	%
Max. PRF @ max. P	30**	30**	kHz
Integrated PLD	905D1S03S	905D1S3J03S	
Emitting Area	75 x 1	85 x 10	μm*μm
Package	S 10	S 10	-
Operating Voltage	+12	+12	VDC

Part Number	LC9-XX-YYY-1S09-S10	LC9-XXX-YYY-3S3J09-S10	Dim.
Wavelength	905	905	nm
Optical Peak Power (NA>0.5)	10 – 20*	40 – 200*	W
Pulse Length	30 – 150*	30 – 150*	ns
Trigger Input	TTL ↑	TTL ↑	-
Max. Duty Cycle	0.1	0.05	%
Max. PRF @ max. P	30**	10**	kHz
Integrated PLD	905D1S09S	905D3S3J09S	
Emitting Area	230 x 1	235 x 400	μm*μm
Package	S 10	S 10	-
Operating Voltage	+12	+12	VDC

## SPECIFICATIONS FOR 1550 nm PLD-MODULE

Part Number	LC5-XX-YYY-1S14-S10	LC5-XX-YYY-4S14-S10	Dim.
Wavelength	1550	1550	nm
Optical Peak Power (NA>0.5)	5 – 12*	10 – 50*	W
Pulse Length	30 – 150*	30 – 150*	ns
Trigger Input	TTL ↑	TTL ↑	-
Max. Duty Cycle	0.1	0.1	%
Max. PRF @ max. P	20**	7**	kHz
Integrated PLD	155G1S14S	155G4S14S	
Emitting Area	350* 1	350* 340	μm*μm
Package	S10	S10	-
Operating Voltage	+12	+12	VDC

\* pls specify required peak power and pulse length within the listed range

\*\* Depending on specified peak power and pulse length



PRODUCT NUMBER DESIGNATIONS

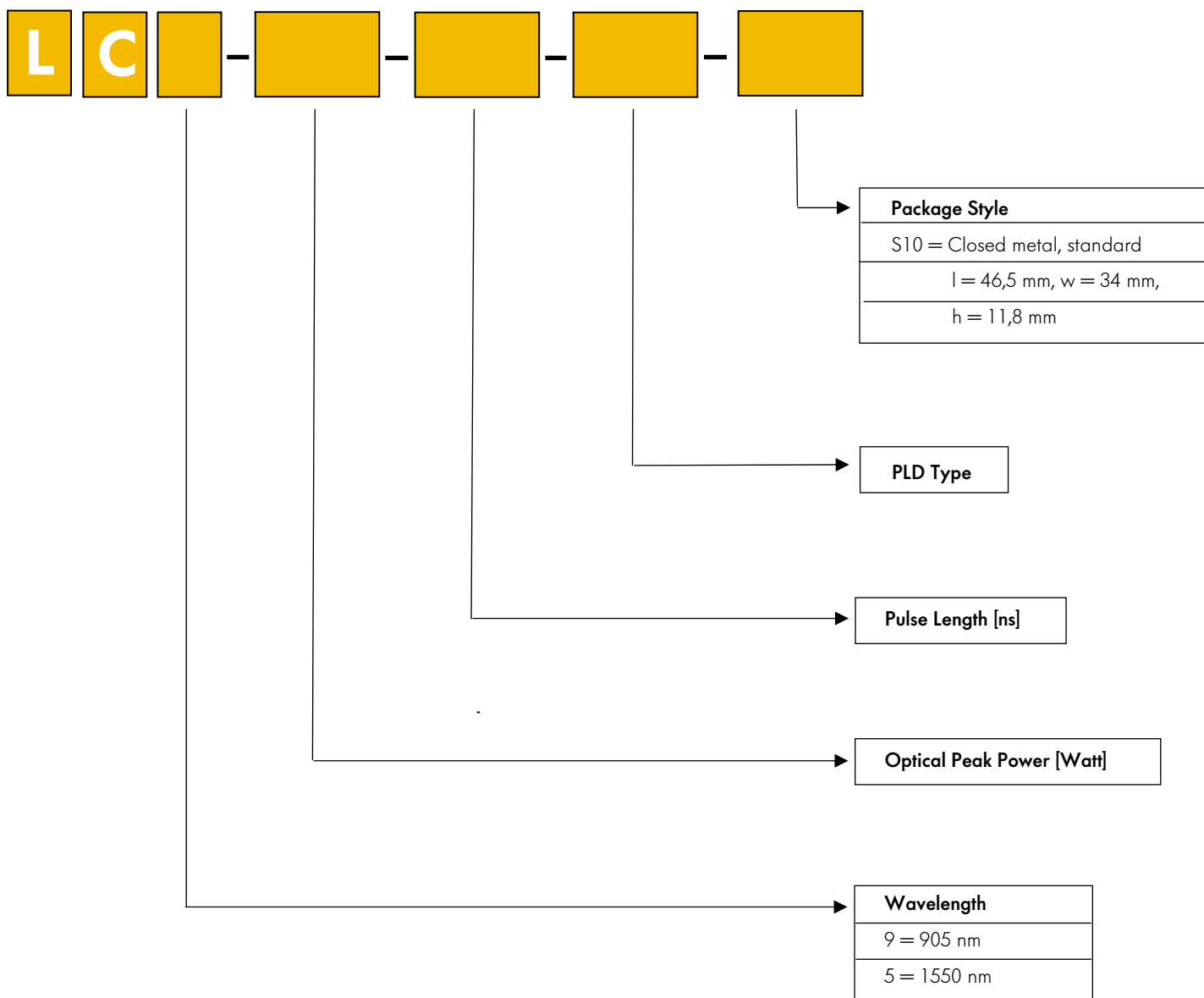

PACKAGE DRAWINGS

S10-package

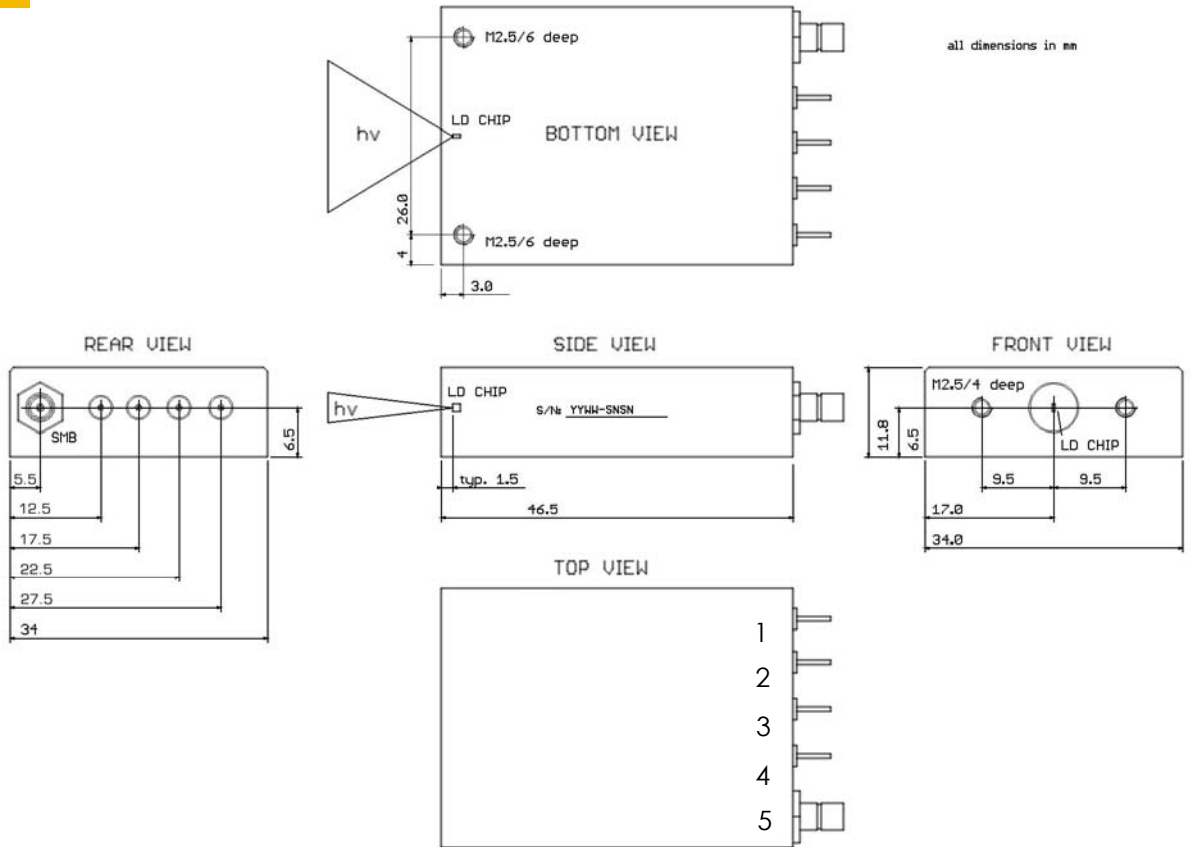

Other packages are available on request.

PIN CONFIGURATION

Pin	LC-Series
1	$V_{oo} = 12 V$
2	GND
3	N.C.
4	N.C.
5	TRG



## PRODUCT CHANGES

LASER COMPONENTS reserves the right to make changes to the product(s) or information contained herein without notice. No liability is assumed as a result of their use or application.

## ORDERING INFORMATION

Products can be ordered directly from LASER COMPONENTS or its representatives. For a complete listing of representatives, visit our website at [www.lasercomponents.com](http://www.lasercomponents.com)  
Custom designed products are available on request.

## LASER SAFETY

### Personal Hazard:

Depending on the mode of operation, these devices emit highly concentrated non visible infrared light which can be hazardous to the human eye. Products which incorporate these devices have to follow the safety precautions given in IEC 60825-1 "Safety of laser products".

### Handling Precautions:

Products are subject to the risks normally associated with sensitive electronic devices including static discharge, transients, and overload.

