

Gooch & Housego

16 channel Digital Frequency Synthesizer: Driver for Acousto-optic Tunable Filter

MSD0XX-YYY-10UC-16x1

FORMER MODEL NUMBER:

(640XX-YYY-10MDFS-16X1-C-A)

DESCRIPTION:

The MSD0XX-YYY-10UC-16x1 is a sixteen channel Digital Frequency Synthesized Driver with the output of each of the 16 channels combined into one output. This driver is typically used for a broadband Acousto-Optic Tunable Filter (AOTF). By appropriate tuning of the 16 channels, the center wavelength and passband shape of the AOTF can be tuned through its usable range. The driver has independent control of frequency, amplitude, and phase of all sixteen frequencies via a standard USB interface. Frequency profiles can be set in immediate mode or up to 64 profiles can be stored for playback. Playback can be synchronized to an external device using separate Sync Out and Sync In signals with programmable delay time. A simple USB control program is provided to assist in development of user control routines. The driver is supplied as a contact cooled OEM module and must be maintained below +40°C.

The product delivered will be manufactured to be compliant with EU Directive 2002/95/EC for Reduction of Hazardous Substance. The product will be manufactured to other standards upon customer request.

KEY FEATURES:

- 40 to 100 MHz or 60 to 150 MHz frequency range typical
- Up to 10 watts Peak Combined Output Power
- 150 mW per channel
- Independent Control of Frequency, Amplitude, and Phase of each Channel
- 200 us Maximum Update Rate
- Operates on 24 VDC

APPLICATIONS:

- RF Driver for an Acousto-Optic Tunable Filter for applications as follows:
- Wavelength selection in sweep mode or random access for AOTFs.
- Filter Shaping for band-pass or band-rejection.
- Wavelength selection in fluorescence microscopy applications
- Filter an image to one or more specific wavelengths in hyper spectral imaging
- Line selection - in super-continuum light sources.
- Raman Spectroscopy - to study vibrational, rotational, and other low-frequency modes
- Used in industrial, medical, or military applications.

As part of our policy of continuous product improvement we reserve the right to change specifications at any time.



光技術をサポートする

株式会社オプトサイエンス

<http://www.optoscience.com>

東京本社 〒160-0014 東京都新宿区内藤町1番地 内藤町ビルディング
TEL: 03 (3356) 1064 FAX: 03 (3356) 3466 E-mail: info@optoscience.com
大阪支店 〒532-0011 大阪市淀川区西中島7-7-2 新大阪ビル西館
TEL: 06 (6305) 2064 FAX: 06 (6305) 1030 E-mail: osk@optoscience.com
名古屋営業所 〒450-0002 名古屋市中村区名駅2-37-21 東海ソフトビル
TEL: 052 (569) 6064 FAX: 052 (569) 8064 E-mail: ngo@optoscience.com

MSD0XX-YYY-10UC-16x1
SPECIFICATIONS

<u>PARAMETER</u>	<u>SPECIFICATION</u>
Frequency Range	40 – 100 MHz or 60-150 MHz typical
Number of Channels	up to 16
Frequency Stability	± .01%
Power Output	5 W max (single channel) 10 W peak power max 150 mW per channel (16 equally spaced channels)
Spurious	-15 dBc (16 channels at 150 mW each)
Harmonics	-15 dBc (16 channels at 150 mW each)
Stored Profiles	up to 64 complete 16 channel profiles
External Sync Delay	0.3-65 ms trigger edge of Camera In, to rising edge of Camera Out
Profile Processing Time	2us per instruction
Minimum Retrigger Time	100ns from rising edge of Camera Out
Trigger Polarity	Falling Edge (Default – NC on Polarity Control Pin) Rising Edge (GND on Polarity Control Pin)
DC Power:	+24V @ 3A max
MAXMIUM RATINGS	
Supply Voltage	+28VDC
Case Temperature	+40°C
CONNECTORS	
RF Output	SMA Female
Sync	5-pin header, TTL levels: Pin 1 Camera In Pin 2 Camera Out Pin 3 GND Pin 4 NC Pin 5 Polarity Control
USB	USB style “B”
Contact Cooled	Driver must be attached to an adequate heat sink
Outline Drawing	53D5126

As part of our policy of continuous product improvement we reserve the right to change specifications at any time.

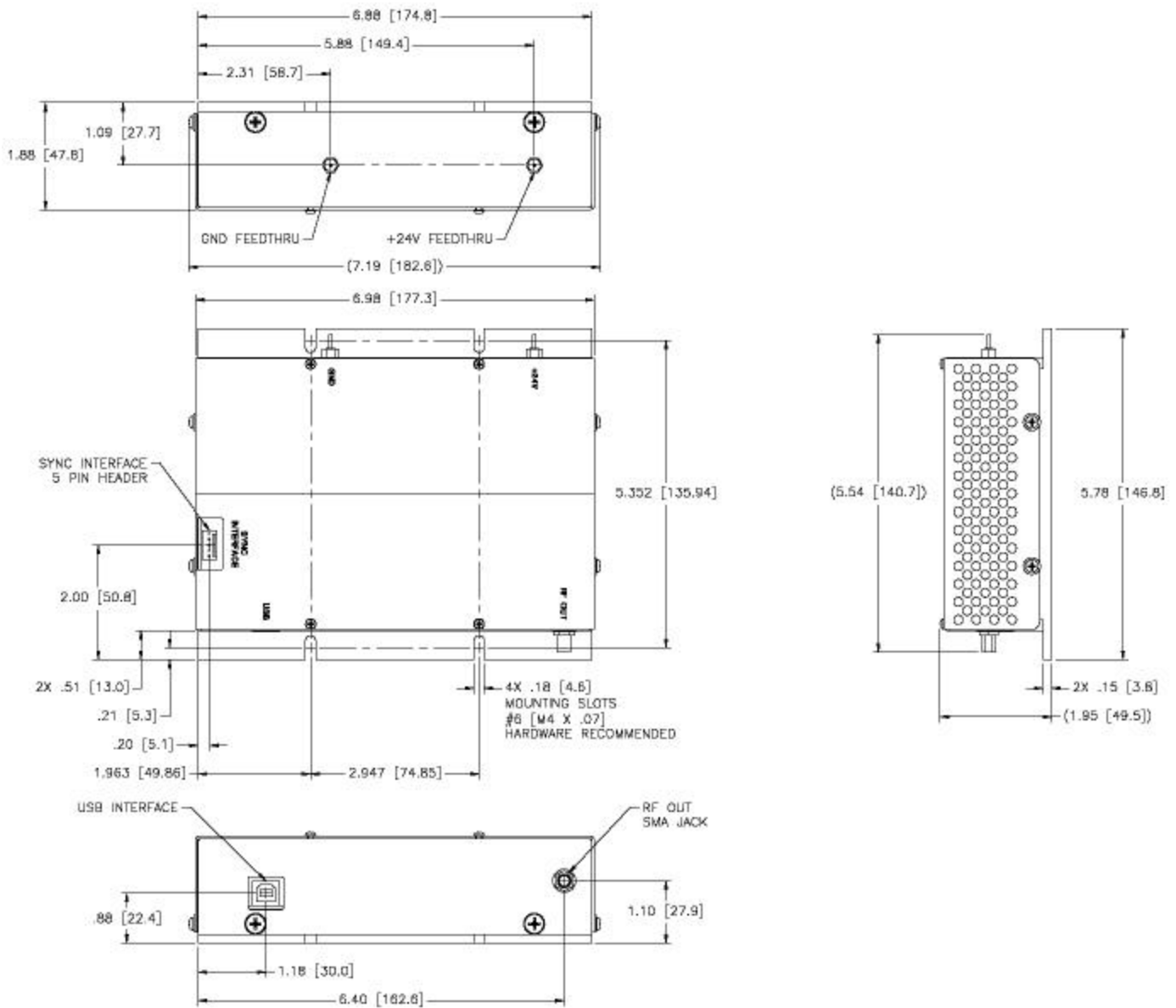
Mechanical Dimensions:
Dimensions in inches and [mm]
53D5126

As part of our policy of continuous product improvement we reserve the right to change specifications at any time.

USB Control Protocol:

The unit operates in two modes; immediate mode and playback mode. In immediate mode, commands are processed as they are sent through the USB connection. This mode supports immediate changes to the state of each channel, the master level control, and data storage. In playback mode, the unit steps through the frequency profiles stored in memory under control of the external Sync In signal. In immediate mode, the system switches to playback mode when instructed to. In playback mode, the system switches to immediate mode when the last profile is reached, or new instructions are sent through the USB.

There are two data formats used in the system: instructions and tokens.

Instructions:

Instructions are commands to the system and are sent through the USB connection during immediate mode. Each instruction is 6 bytes long. (If the required length is less than 6 bytes, fill the extra bytes with zeros)

Master Instruction List:

Code	Data	Data	Data	Data	Data	Function
02h	xx	xx	xx	xx	xx	Clear Buffer (Sets data entry to profile 0)
03h	xx	xx	xx	xx	xx	Enter Playback Mode (Profile 0 loaded initially)
05h	cc	dd	dd	dd	dd	Immediately execute command token 'cc'
06h	cc	dd	dd	dd	dd	Load Token into current profile
07h	dd	xx	xx	xx	xx	Load Sync delay (0.3 – 65 ms)
08h	xx	xx	xx	xx	xx	Enter Continuous Loop Playback Mode (Profile 0 loaded initially)

'cc' = command; 'dd' = data; 'xx' = don't care

Tokens:

Tokens are configuration statements used during a profile. Tokens are 5 bytes long. (If the required length is less than 5 bytes, fill the extra bytes with zeros). Each profile can contain from 0 to 127 tokens.

There are two types of tokens, Configuration Tokens and Command Tokens. Configuration Tokens are used to set information into the register map of each DDS chip. Command Tokens are used to set any values not directly represented in the register map. The format for the tokens is:

Configuration Token:

0	cc	rr	rr	rr	rr	dd	dd	dd	dd
---	----	----	----	----	----	----	----	----	----

'cc' = chip identifier, 'rrrrr' = register address, 'dd' = data (Size determined by register)

Command Token:

1	ffff	ffff	ffff	ffff	ffff	dd	xx	xx	xx
---	------	------	------	------	------	----	----	----	----

'fffff' = function identifier, 'dd' = data (Size determined by function)

As part of our policy of continuous product improvement we reserve the right to change specifications at any time.

Master Token List:

	Token	Data	Data	Data	Data	Description
DDS chip 0	00h	dd	xx	xx	xx	Channel Select Register
	01h	msb	dd	lsb	xx	Function Register 1
	02h	msb	lsb	xx	xx	Function Register 2
	03h	msb	dd	lsb	xx	Channel Function Register
	04h	msb	dd	dd	lsb	Channel Frequency Tuning Word
	05h	msb	lsb	xx	xx	Channel Phase Offset Word
	06h	msb	dd	lsb	xx	Amplitude Control
DDS chip 1	20h	dd	xx	xx	xx	Channel Select Register
	21h	msb	dd	lsb	xx	Function Register 1
	22h	msb	lsb	xx	xx	Function Register 2
	23h	msb	dd	lsb	xx	Channel Function Register
	24h	msb	dd	dd	lsb	Channel Frequency Tuning Word
	25h	msb	lsb	xx	xx	Channel Phase Offset Word
	26h	msb	dd	lsb	xx	Amplitude Control
DDS chip 2	40h	dd	xx	xx	xx	Channel Select Register
	41h	msb	dd	lsb	xx	Function Register 1
	42h	msb	lsb	xx	xx	Function Register 2
	43h	msb	dd	lsb	xx	Channel Function Register
	44h	msb	dd	dd	lsb	Channel Frequency Tuning Word
	45h	msb	lsb	xx	xx	Channel Phase Offset Word
	46h	msb	dd	lsb	xx	Amplitude Control
DDS chip 3	60h	dd	xx	xx	xx	Channel Select Register
	61h	msb	dd	lsb	xx	Function Register 1
	62h	msb	lsb	xx	xx	Function Register 2
	63h	msb	dd	lsb	xx	Channel Function Register
	64h	msb	dd	dd	lsb	Channel Frequency Tuning Word
	65h	msb	lsb	xx	xx	Channel Phase Offset Word
	66h	msb	dd	lsb	xx	Amplitude Control
All DDS chips	E0h	dd	xx	xx	xx	Channel Select Register
	E1h	msb	dd	lsb	xx	Function Register 1
	E2h	msb	lsb	xx	xx	Function Register 2
	E3h	msb	dd	lsb	xx	Channel Function Register
	E4h	msb	dd	dd	lsb	Channel Frequency Tuning Word
	E5h	msb	lsb	xx	xx	Channel Phase Offset Word
	06h	msb	dd	lsb	xx	Amplitude Control
	80h	xx	xx	xx	xx	Profile Complete
	81h	dd	xx	xx	xx	Set master level control to 'dd'

'dd' = data, 'msb' = most significant byte, 'lsb' = least significant byte, 'xx' = don't care

As part of our policy of continuous product improvement we reserve the right to change specifications at any time.

Sample Programming Stream:

	02h	Xx	xx	xx	xx	xx	Clear Buffer
Profile 0	06h	81h	00h	xx	xx	xx	Set Master Output to Min
	06h	00h	16h	xx	xx	xx	Select Chip 0, Channel 0
	06h	03h	dd	dd	dd	xx	Write channel function
	06h	04h	dd	dd	dd	dd	Write Frequency
	06h	05h	dd	dd	dd	xx	Write Phase
	06h	06h	dd	dd	dd	xx	Write Amplitude
	06h	00h	26h	xx	xx	xx	Select Chip 0, Channel 1
	06h	03h	dd	dd	dd	xx	Write channel function
	06h	04h	dd	dd	dd	dd	Write Frequency
	06h	05h	dd	dd	dd	xx	Write Phase
	06h	06h	dd	dd	dd	xx	Write Amplitude
				...			
	06h	00h	26h	xx	xx	xx	Select Chip 0, Channel 1
	06h	03h	dd	dd	dd	xx	Write channel function
	06h	04h	dd	dd	dd	dd	Write Frequency
	06h	05h	dd	dd	dd	xx	Write Phase
	06h	06h	dd	dd	dd	xx	Write Amplitude
	06h	81h	dd	xx	xx	xx	Set master Output to 'dd'
	06h	80h	xx	xx	xx	xx	End Profile
Profile 1	06h	81h	00h	xx	xx	xx	Set Master Output to Min
	06h	00h	16h	xx	xx	xx	Select Chip 0, Channel 0
	06h	03h	dd	dd	dd	xx	Write channel function
	06h	04h	dd	dd	dd	dd	Write Frequency
				...			
	06h	80h	xx	xx	xx	xx	End Profile
	03h	xx	xx	xx	xx	xx	Enter Playback Mode

In this example, the instruction stream does the following:

- Clears the profile buffer.
- Loads Profile 0.
- Loads Profile 1.
- Continues to load profiles until it reaches the end profile marker.
- Enters playback mode.

When one of these profiles is loaded, the following occurs:

- The master power level is set to a minimum.
- Channel 0, on chip 0, is selected.
- The active channel is configured.
- The active channel is assigned a frequency.
- The active channel is assigned a phase.
- The active channel is assigned an amplitude.
- Channel 1, on chip 1 is selected.
- The process repeats for the remaining channels.
- The master output level is set.
- The system waits for the next external trigger.

As part of our policy of continuous product improvement we reserve the right to change specifications at any time.

Register map:

	Register Name (Address)	Bit Range	Bit 7 (MSB)	Bit 6	Bit 5	Bit 4	Bit 3	Bit 2	Bit 1	Bit 0 (LSB)	Default Value	
Control Registers	Channel Select Register (CSR) (0x00)	<7:0>	Aux Chan 3 (W/R enable)	Aux Chan 2 (W/R enable)	Primary Chan 1 (W/R enable)	Aux Chan 0 (W/R enable)	Must be 0	Must be 11 <2:1>		Must be 0	0xF6	
	Function Register 1 (FR1) (0x01)	<7:0>	Must be 0	Must be 0	Must be 0	Must be 0	Must be 0	Must be 0	Must be 0	Must be 0	0x00	
		<15:8>	Must be 0	Must be 000 <14:12>			Must be 00 <11:10>		Must be 00 <9:8>		0x00	
		<23:16>	Must be 1	Must be 00101 <22:18>				Must be 00 <17:16>		0x94		
	Function Register 2 (FR2) (0x02)	<7:0>	Must be 0	Must be 0	Must be 0	Must be 0	Open <3:2>		Must be 00 <1:0>		0x00	
		<15:8>	Must be 0	Must be 0	Must be 1	Must be 0	Open <11:10>		Open <9:8>		0x20	
	Channel Registers	Channel Function (CFR) (0x03)	<7:0>	Must be 0	Must be 0	Must be 0	Must be 0	Must be 0	Must be 0	Must be 0	Must be 0	0x00
<15:8>			Must be 0	Must be 0	Must be 0	Open	Open	Must be 0	Must be 00 <9:8>		0x00	
<23:16>			Must be 00 <23:22>		Open <21:19>			Must be 111 <18:16>			0x07	
Frequency Tuning Word 0 (CTW0) (0x04)		<7:0>	Frequency Tuning Word 0 <7:0>									0x00
		<15:8>	Frequency Tuning Word 0 <15:8>									0x00
		<23:16>	Frequency Tuning Word 0 <23:16>									0x00
		<31:24>	Frequency Tuning Word 0 (MSB = <31:24>									0x00
Phase Offset Word 0 (CPOW0) (0x05)		<7:0>	Phase Offset Word 0 <7:0>									0x00
		<15:8>	Open <15:14>			Phase Offset Word 0 <13:8>						0x00
Amplitude Control (ACR) (0x06)		<7:0>	Amplitude scale factor <7:0>									0x00
		<15:8>	Must be 00 <15:14>		Open	Must be 1	Must be 0	Must be 0	Amplitude scale factor <9:8>		0x10	
		<23:16>	Must Be 0 <23:16>									0x00

As part of our policy of continuous product improvement we reserve the right to change specifications at any time.

Ordering Codes:
Example: MSD040-100-10UC-16x1

A 10 watt, 40 to 100 MHz, Digitally Frequency Synthesized, RF Driver with Serial Digital Modulation via USB Port. Control of Frequency, phase, and Amplitude. Up to 64 stored profiles. Delivered as a, RoHS compliant, contact cooled, OEM Module. Typically used for an AOTF Device needing random access or filter shaping.

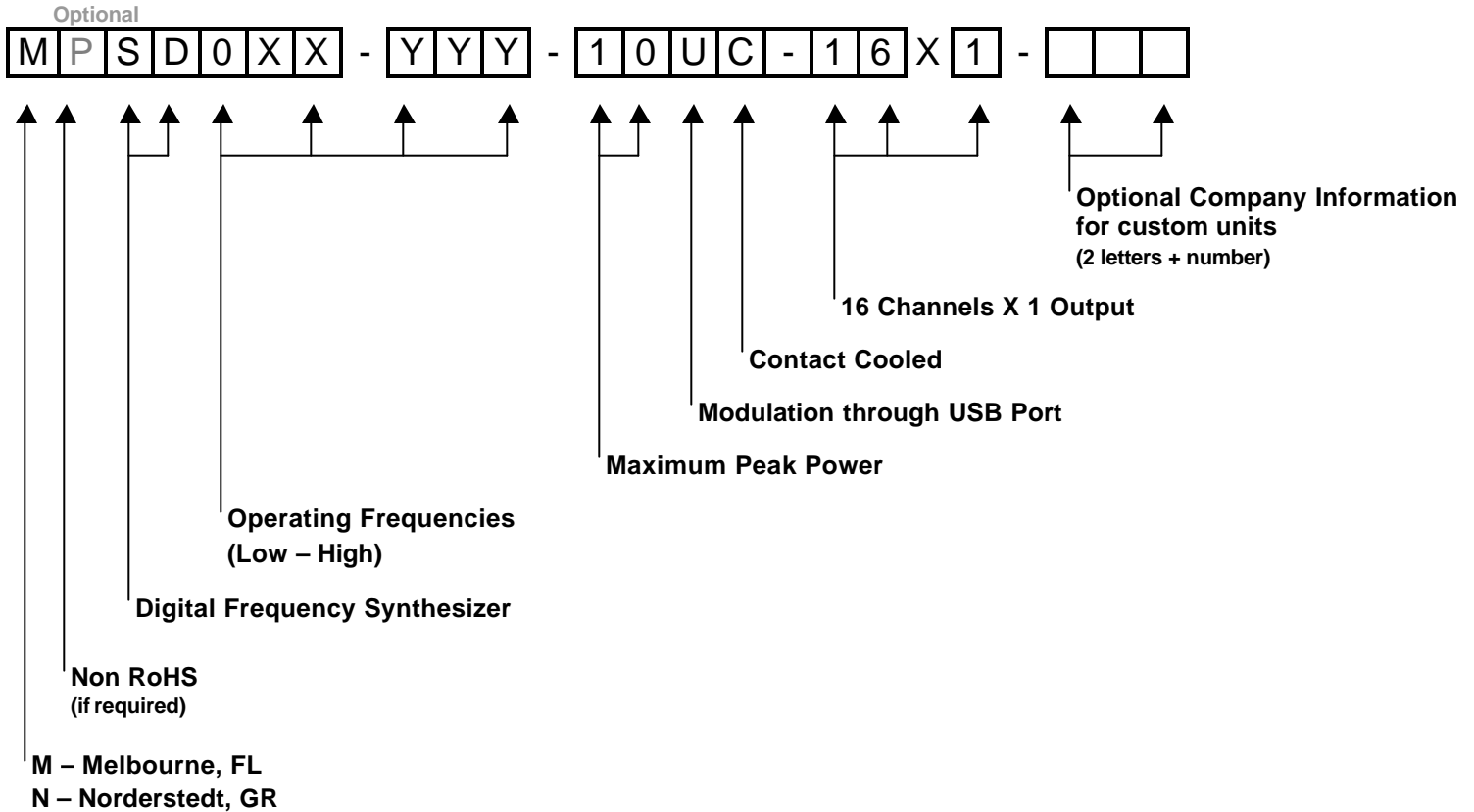
Technical Assistance & Customization

Our Engineering and Sales team are available to discuss your requirements and will assist you in selecting the most appropriate acousto-optic AOD or AOTF/ Diver combination for your application.

For More Information, Contact: sales@goochandhousego.com www.goochandhousego.com

As part of our policy of continuous product improvement we reserve the right to change specifications at any time.