

Gooch & Housego

**8 Channel Digital Frequency Synthesizer:
Driver for Acousto-optic Deflector
or Acousto-optic Tunable Filter**

MSD040-150-0.2ADM-A5H-8X1

FORMER MODEL NUMBER:

(64040-150-0.2ADMDFS-8X1-A)



Description:

The MSD040-150-0.2ADM-A5H-8X1 is an 8 channel Digital Frequency Synthesizer driver with the output signals combined into one output for use with an Acousto-Optic Deflector (AOD) allowing up to 8 simultaneous optical beams to be output from the AOD or up to 8 wavelengths output from an Acousto-Optic Tunable Filter (AOTF). The driver allows independent analog (intensity) and digital (blanking) control of up to eight wavelengths / beams of light. The frequency, phase and maximum power for each channel can be setup through software* interfaced through the USB port. The driver requires forced air cooled and must be maintained below +40°C.

The product delivered will be manufactured to be compliant with EU Directive 2002/95/EC for Reduction of Hazardous Substance. The product will be manufactured to other standards upon customer request.

Key Features:

- 40 to 150 MHz
- Up to 8 Frequencies Simultaneously Output
- 0.2 watts Power Output per Channel
- Analogue (intensity) Modulation
- TTL Digital (Blanking) Modulation
- Random Access to any Frequency
- Frequency Settling Time: 250 ns
- Operates on +24 VDC and +5 VDC**

Applications:

- RF Driver for an Acousto-Optic Deflectors or Tunable Filters used in the following applications:
 - Beam shaping in AODs
 - Multiple beam deflection in AODs
 - Filter band pass shaping in AOTFs
 - Wavelength selection in fluorescence microscopy applications and Laser displays using AOTFs
- Super-continuum light sources using AOTFs
- Line selection in Agile Light Sources
- Hyperspectral Imaging
- Real-time online monitoring of processes
- Used in industrial, medical, or military applications.



光技術をサポートする

株式会社オプトサイエンス

<http://www.optoscience.com>

東京本社 〒160-0014 東京都新宿区内藤町1番地 内藤町ビルディング
TEL: 03 (3356) 1064 FAX: 03 (3356) 3466 E-mail: info@optoscience.com
大阪支店 〒532-0011 大阪市淀川区西中島7-7-2 新大阪ビル西館
TEL: 06 (6305) 2064 FAX: 06 (6305) 1030 E-mail: osk@optoscience.com
名古屋営業所 〒450-0002 名古屋市中村区名駅2-37-21 東海ソフトビル
TEL: 052 (569) 6064 FAX: 052 (569) 8064 E-mail: ngo@optoscience.com

MSD040-150-0.2ADM-A5H-8X1
SPECIFICATIONS

<u>PARAMETER</u>	<u>SPECIFICATION</u>	
Number of Channels:	8	
Frequency Stability:	± .01 %	
Power Out:	50 – 200 mW per channel	
Tuning Range:	40 to 150 MHz in 1 kHz Steps	
Analog Inputs (8):	0-5 volts into 10 k ohms	
Blanking Inputs (8):	TTL with 4.7 k ohms pull up	
	TTL HIGH or open	= full output (not blanked)
	TTL LOW	= minimum output (blanked)
Rise/Fall Time:	150 ns maximum	
Extinction Ratio:	70 dB minimum	
Thermoelectric Cooler Controller:	On board controller available for AO devices that have TECs for thermal stability.	
Cooling	Forced Air Cooling. Must be maintained below 40 ⁰ C.	
Applied Power:	24 VDC @ 2A maximum	
	** 5 VDC @ 3A maximum Required if using the TEC	
Connectors:		Part no.
RF Out:	BNC Female	1-1478035-0
Modulation In:	25 Pin D-Sub Female	RDM25SA5
Reference Out	SMB Male	1060464-1
RS-232 Interface:	9 Pin D	RDM9SA5
USB Interface:	USB B style receptacle*	61729-0010BLF
Power + TEC	6 pin	1-794448-1
Remote (not used currently)	5 pin SPOX	22-05-7055
Outline Drawing:	53D4875	

*The software driver connects the communications program to a standard USB port and emulates a standard COM port. The software driver is available from FTDI (<http://www.ftdichip.com/Drivers/VCP.htm>)

As part of our policy of continuous product improvement we reserve the right to change specifications at any time.

Figure 2
Pinout 25 pin D-sub control connector

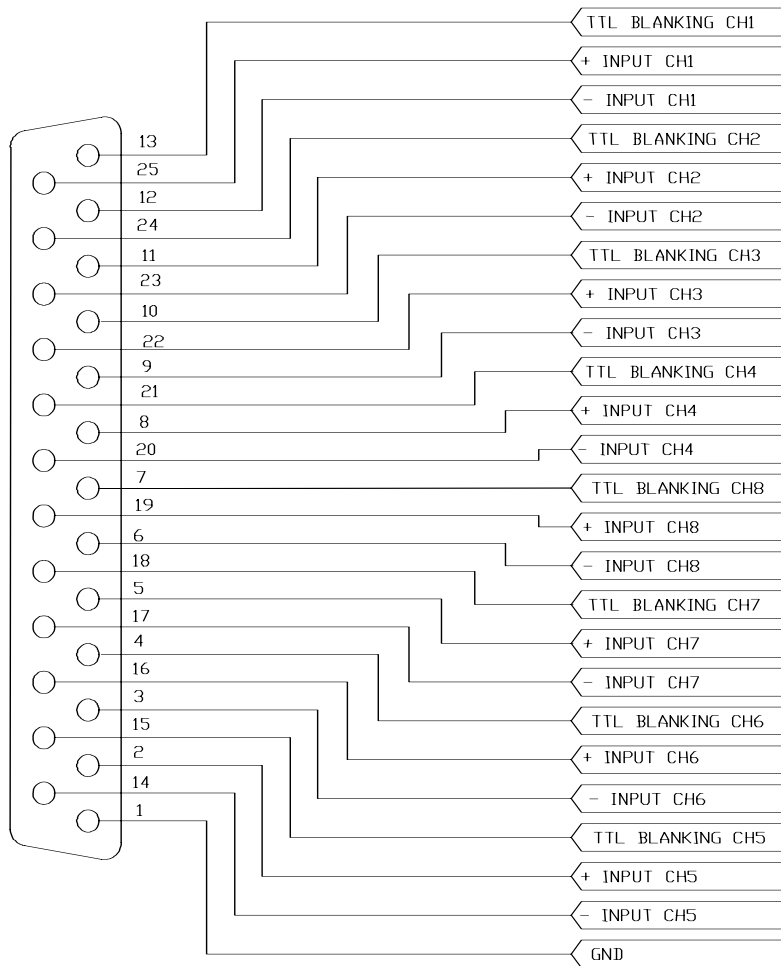

As part of our policy of continuous product improvement we reserve the right to change specifications at any time.

Figure 3
Pinout of TEC connector

Pin No.	Name
1	No Connection
2	GND (Thermistor)
3	No Connection
4	Thermistor
5	TECP
6	TECN

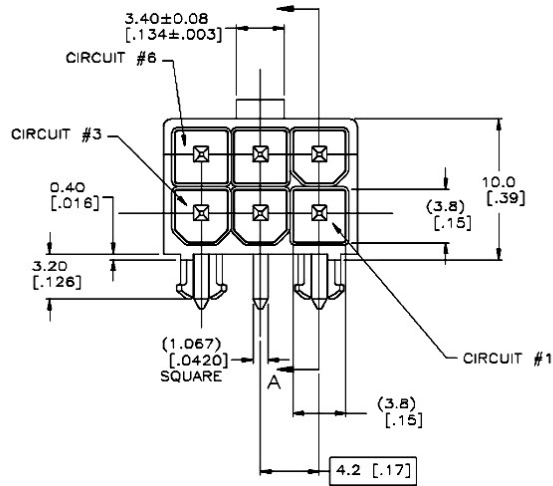

Figure 4
Pinout Power connector

Pin No.	Name
1	+28V
2	GND
3	+5 V TEC
4	NC
5	GND
6	NC

As part of our policy of continuous product improvement we reserve the right to change specifications at any time.

Figure 5
RS 232 connector

Pin No.	Name	Dir	Notes / Description
1	DCD	IN	No Connection
2	RD	IN	Receive Data (a.k.a RxD, Rx). Arriving data from DCE.
3	TD	OUT	Transmit Data (a.k.a TxD, Tx). Sending data from DTE.
4	DTR	OUT	No Connection
5	SGND	-	Ground
6	DSR	IN	No Connection
7	RTS	OUT	No Connection
8	CTS	IN	No Connection
9	RI	IN	No Connection

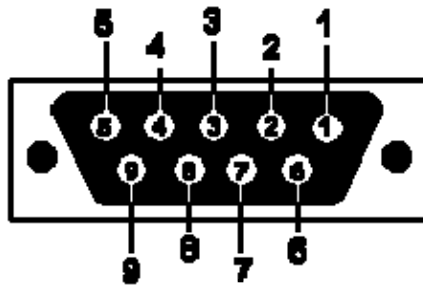

DB9: View looking into female connector

As part of our policy of continuous product improvement we reserve the right to change specifications at any time.

Ordering Codes:
Example: MSD040-150-0.2ADM-A5H-8X1

An 8 Channel, 0.2 watt per channel, 40 to 150 MHz, Digitally Frequency Synthesized RF Driver with TTL Digital and 0 to 5 volt Analog Modulation. Delivered as an, RoHS compliant, forced air cooled, OEM module. Typically used for an AOD or AOTF Device needing random access and multiple drive frequencies at the same time.

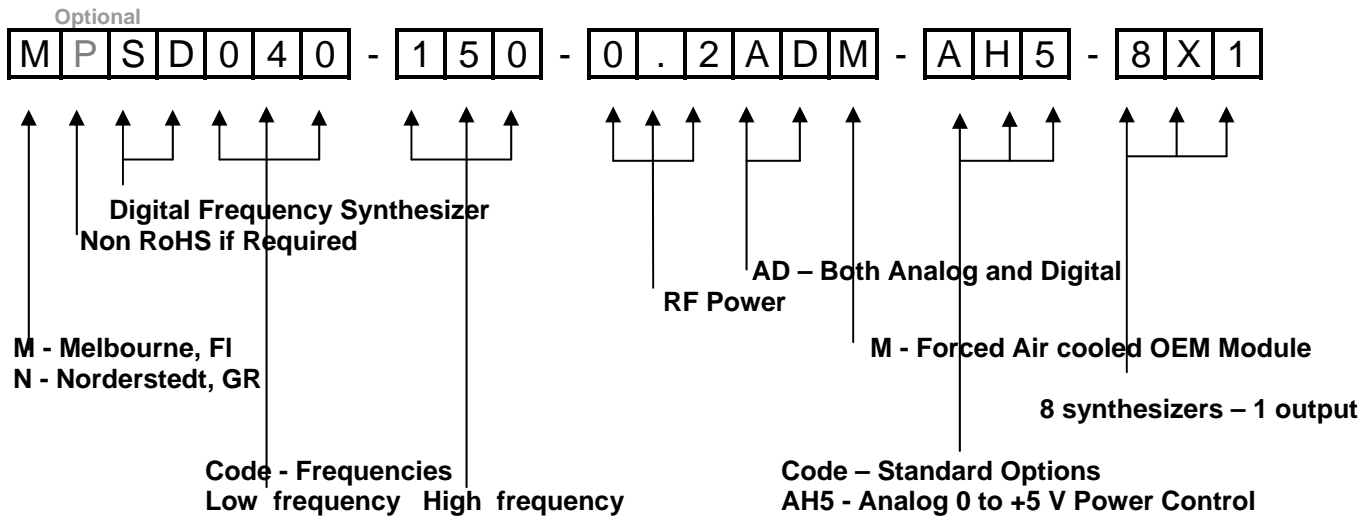
Technical Assistance & Customization

Our Engineering and Sales team are available to discuss your requirements and will assist you in selecting the most appropriate AOD or AOTF/ Diver combination for your Application.

For More Information, Contact: sales@goochandhousego.com www.goochandhousego.com

As part of our policy of continuous product improvement we reserve the right to change specifications at any time.