

# Gooch & Housego

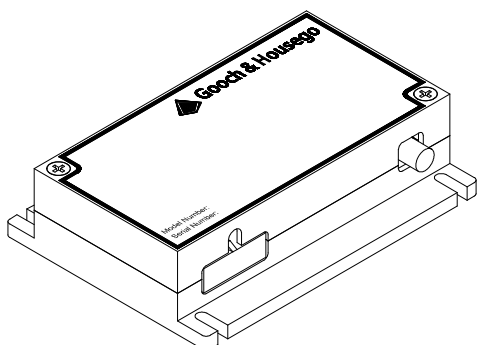

## *Acousto-optic Modulator Driver:*

## **MHC150-2AC-A1-TQ2**

### **Description:**

The MHC150-2AC-A1-TQ2 is a RF Driver in standard frequencies of 150 MHz (factory set) and up to 2 watts power output into a 50 ohm load. A 0 to 1 V Analog Modulation Input enables control of the RF output power. The output pulse width follows the input pulse width.

The product delivered will be manufactured to be compliant with EU Directive 2002/95/EC for Reduction of Hazardous Substance. The product will be manufacture to other standards upon customer request.

### **Key Features:**

- 150MHz
- 0.01% Quartz Stabilized
- 2 watts RF Power output
- Analog Modulation  
< 20 ns rise time
- Operates on 15 VDC

### **Applications:**

- RF Driver for an Acousto-Optic Modulator Device requiring 2 watts drive power.
- Used in industrial, medical, or military applications.

**For More Information, Contact: [sales@goochandhousego.com](mailto:sales@goochandhousego.com) [www.goochandhousego.com](http://www.goochandhousego.com)**

As part of our policy of continuous product improvement we reserve the right to change specifications at any time.



光技術をサポートする

**株式会社オプトサイエンス**

<http://www.optoscience.com>

東京本社 〒160-0014 東京都新宿区内藤町1番地 内藤町ビルディング  
TEL:03(3356)1064 FAX:03(3356)3466 E-mail:info@optoscience.com  
大阪支店 〒532-0011 大阪市淀川区西中島7-7-2 新大阪ビル西館  
TEL:06(6305)2064 FAX:06(6305)1030 E-mail:osk@optoscience.com  
名古屋営業所 〒450-0002 名古屋市中村区名駅2-37-21 東海ソフトビル  
TEL:052(569)6064 FAX:052(569)8064 E-mail:ngo@optoscience.com

**MHC150-2AC-A1-TQ2**
**SPECIFICATIONS:**
**PARAMETER:**
**SPECIFICATION:**

Output Frequency: (150)	150 MHz ± 0.01% Quartz Stabilized
Spurious Levels:	-40 dBc Maximum
Harmonic Distortion:	-15 dBc Maximum
Analog Input: (A) (-A1)	0-1 volt into 50 ohms 1 volt = Full RF Power 0 = RF Power off
Extinction Ratio:	40 dB Minimum
RF Rise / Fall Time:	20 ns Typical, 10 ns > 210 MHz P <sub>RF</sub> : 10 to 90 %
RF Output Power: (2)	2 watts Nominal
Output Impedance:	50 ohms Nominal
Supply Voltage:	15 VDC
Supply Current:	1 amps Maximum
Cooling: (C)	This driver must be attached to a heatsink capable of dissipating 15 watts.

**MAXIMUM RATINGS:**

Supply Voltage:	+18 VDC
Power Output:	No DC Feedback Allowed
Case Temperature:	+ 55° C

**CONNECTORS & MECHANICAL:**

RF Output Connector:	SMA Female
Connector:	12 pin Molex p/n 43045-1221 Connector

P1 –	nc	P7 –	nc
P2 –	nc	P8 –	nc
P3 –	nc	P9 –	nc
P4 –	Gnd	P10 –	Analog Mod Gnd
P5 –	nc	P11 –	nc
P6 –	Analog Mod in	P12 –	Vcc +15 VDC

Mating Connector:	Dual Row Receptacle - Molex PN: 43025-1200 or - Molex PN: 43025-1208 Female crimp terminals - Molex PN: 43030
-------------------	---

**For More Information, Contact: [sales@goochandhousego.com](mailto:sales@goochandhousego.com) [www.goochandhousego.com](http://www.goochandhousego.com)**

As part of our policy of continuous product improvement we reserve the right to change specifications at any time.

**Mechanical Dimensions:**

**Dimensions in inches and [mm]**

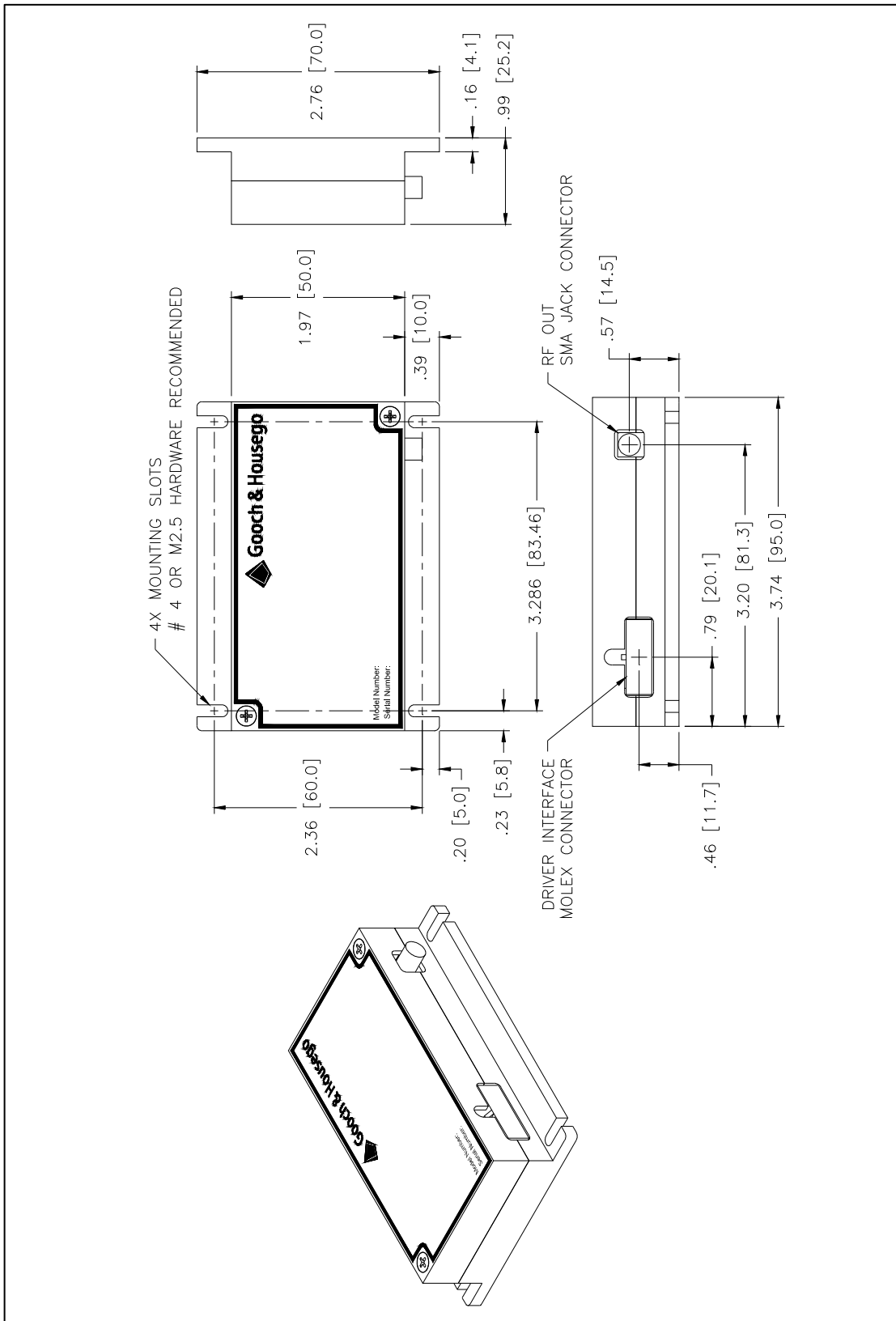

**For More Information, Contact: [sales@goochandhousego.com](mailto:sales@goochandhousego.com) [www.goochandhousego.com](http://www.goochandhousego.com)**

As part of our policy of continuous product improvement we reserve the right to change specifications at any time.

Ordering Codes:

Example: **MHC150-2AC-A1-TQ2**

M	H	C	1	5	0	-	2	A	C	-	A	1	-	T	Q	2
---	---	---	---	---	---	---	---	---	---	---	---	---	---	---	---	---

The model number for this unit indicate the following:

Made in Gooch & Housego's Melbourne location, High Power, Compact Package, 150 MHz @ 2 watts RF output, Analog modulation, Contact cooled case, 0-1 volt analog option, for Torquay customer, version 1

### Technical Assistance & Customization

Our Engineering and Sales team are available to discuss your requirements and will assist you in selecting the most appropriate acousto-optic Modulator/ Diver combination for your laser.

For More Information, Contact: [sales@goochandhousego.com](mailto:sales@goochandhousego.com) [www.goochandhousego.com](http://www.goochandhousego.com)

As part of our policy of continuous product improvement we reserve the right to change specifications at any time.