

Spatial Light Modulators

A spatial light modulator (SLM) is an electrically programmable device that modulates light according to a fixed spatial (pixel) pattern. SLMs have an expanding role in several optical areas where light control on a pixel-by-pixel basis is critical for optimum system performance. SLMs are typically used to control incident light in amplitude-only, phase-only or the combination (phase-amplitude).

Boulder Nonlinear Systems, Inc. (BNS) manufactures and sells liquid crystal spatial light modulators for a variety of photonics applications. Instead of using off-the-shelf displays, BNS has designed multiple SLMs specifically for these applications. This custom design approach allows us to offer products that are optimized for use in photonics applications. Our manufacturing processes have been developed to yield optically flat devices tuned to maximize performance at a variety of nominal wavelengths from the visible through the near infrared (NIR). Prototype SLMs can also be purchased for ultraviolet (UV) short-wave infrared (SWIR), mid-wave infrared (MWIR), and long-wave infrared (LWIR).

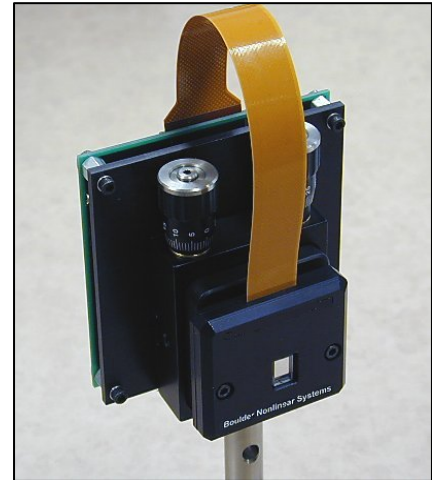

Key features of our SLMs include high speed phase or amplitude modulation, high optical efficiency, optically flat, reflection-mode operation, and a complete, user-friendly graphical software interface.

Unique BNS Advantages

- A variety of modulation options:
 - Phase Only
 - Amplitude Only
 - Combined Phase and Amplitude
- Customized Liquid Crystal for your application
- Wavelengths include: 360 nm, 485 – 1650 nm, 1.5 – 2.5 μ m, 3 – 5 μ m, 8 – 12 μ m
- High Efficiency – up to 95% Zero Order Diffraction Efficiency with 100% Fill Factor
- No Phase Ripple (not a microdisplay)
- DVI, PCIe, or PCI Drivers available
- Software Developer Kits available
 - MatLab, C++, LabView

Applications

- Beam steering
- Optical tweezers
- Diffractive optics
- Optical correlation
- Wavefront correction
- Ultra-fast pulse shaping
- Optical data processing
- Holographic data storage
- Programmable phase masks
- Image processing/analysis

Phase / Amplitude / or Both

Because BNS offers custom liquid crystal options, we can provide our customers with the ability to achieve both Phase and Amplitude modulation with one SLM. Our Nematic Liquid crystal (normally used for a Phase Modulator) can be used as an Amplitude Modulator by altering the optical set-up.



光技術をサポートする

株式会社オプトサイエンス

<http://www.optoscience.com>

東京本社 〒160-0014 東京都新宿区内藤町1番地 内藤町ビルディング
TEL:03(3356)1064 FAX:03(3356)3466 E-mail:info@optoscience.com
大阪支店 〒532-0011 大阪市淀川区西中島7-7-2 新大阪ビル西館
TEL:06(6305)2064 FAX:06(6305)1030 E-mail:osk@optoscience.com
名古屋営業所 〒450-0002 名古屋市中村区名駅2-37-21 東海ソフトビル
TEL:052(569)6064 FAX:052(569)8064 E-mail:ngo@optoscience.com

XY Nematic Series SLMs – Phase, Amplitude or Both

The Boulder Nonlinear Systems, Inc. (BNS) XY Nematic Series Spatial Light Modulators (SLMs) are designed for versatility and ease of use in typical optical laboratory environments. The XY Nematic Series SLMs are optimized to provide a full wave (2π) of phase stroke upon reflection at one of several nominal design wavelengths. These SLMs provide phase-only modulation when the input light source is linearly polarized in the vertical axis. Amplitude modulation, with some phase-coupling, can also be achieved simply by rotating the input polarization by 45° .

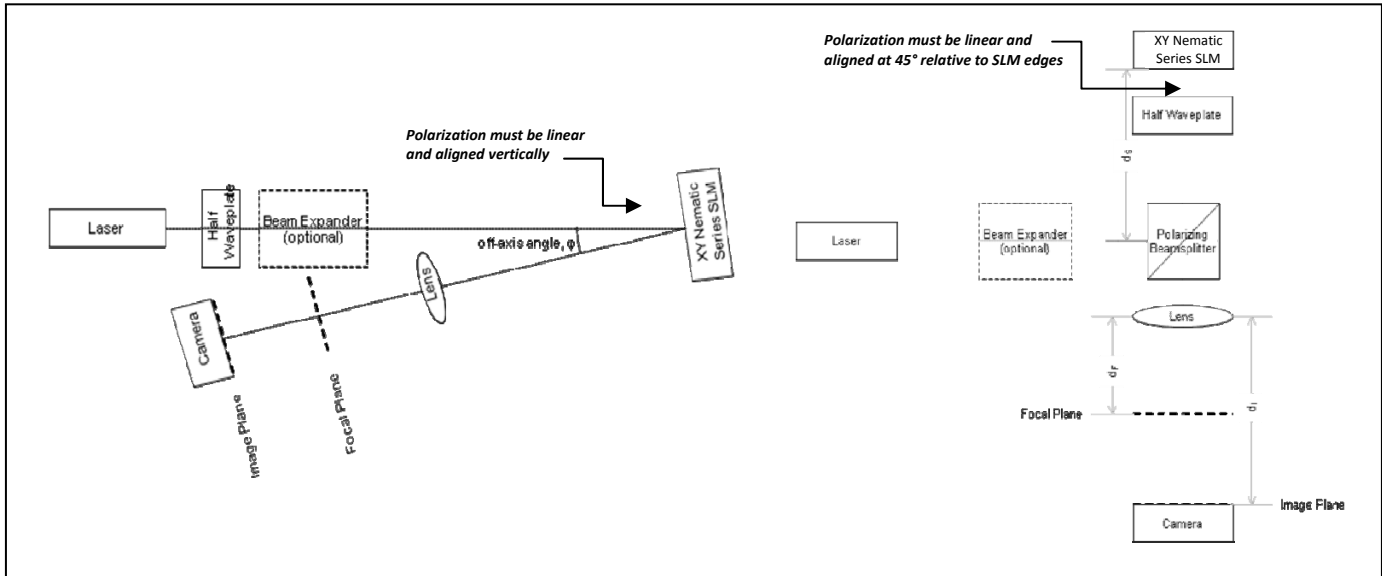

Nematic SLM used for Phase-only Modulation

Nematic SLM used for Amplitude Modulation

XY Ferroelectric Series SLMs – Amplitude or Polarization Rotation

Boulder Nonlinear Systems, Inc. (BNS) XY Ferroelectric Series Spatial Light Modulators (SLMs) are designed to provide amplitude-only modulation via an analog polarization rotation of up to 90° .

These SLMs are optimized to provide very fast frame rates (up to 1 kHz). However, as with all ferroelectric liquid crystal devices, the duty cycle is limited to a maximum of 50:50 (drive requirements force use of true image for half of cycle and inverse image for other half).

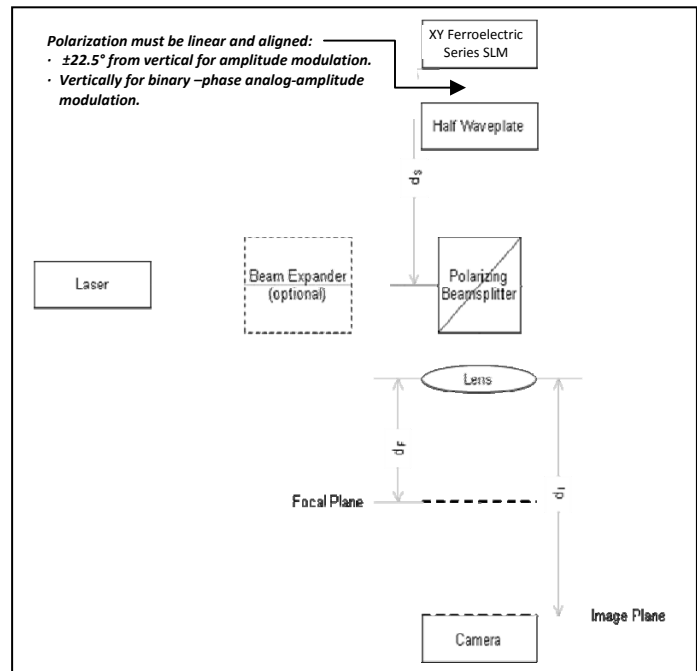

Ferroelectric SLM used for Amplitude Modulation

Unique BNS SLM Features

BNS has developed many unique liquid crystal spatial light modulators over the past two decades. Through this development process, there has been an advancement of SLM performance unmatched by any other company. Such performance enhancement includes **Sub-millisecond frame loading** to prevent phase droop and addressing latency; **100% fill factor** to reduce higher-order diffraction, **Intra-pixel-pair modulo- 2π phase transitions** to maximize space bandwidth, and customized manufacturing processes to achieve optically flat performance, and Phase-only liquid crystal response times.

With properly designed liquid crystal on silicon (LCoS) technology, the output modulation depends only on the type of liquid crystal (LC), the alignment layers, and the LC orientation with regard to the input light’s polarization. Several types of high-resolution spatial light modulators have been demonstrated using different combinations of these parameters. Some of the more standard are:

- *Sub-millisecond analog amplitude* – true gray-level at rates exceeding 1 kHz with ferroelectric liquid crystal (FLC), using the XY Ferroelectric Series SLMs.
- *Phase-only* - 0 to 2π (or greater) of phase stroke (optical path difference) with no amplitude bleed with parallel-aligned nematic LC, using the XY Nematic Series SLMs.
- *Complex amplitude* - the degree of amplitude and phase produced by a modulator is selectively controlled through polarization, using either the XY Ferroelectric Series or the XY Nematic Series SLMs.

In addition to the above modulators, which are commonly available, there are other possibilities (some are listed below). These modulators use less conventional liquid crystals cells, require more complicated addressing techniques and generally require higher voltage.

- *Sub-millisecond phase-only* – no amplitude coupling.
- *Sub-millisecond nondispersive phase-mostly* (achromatic phase shifter) - nearly one wave of phase shift that is wavelength independent.
- *Polarization-independent phase-only* – phase modulates randomly polarized light.

High-speed Addressing

BNS loads every pixel with an 8-bit or 16-bit data several times per millisecond. This high speed addressing scheme eliminates phase droop as demonstrated in the figure below. There is significant data-dependent ripple caused by slowly addressing the modulator (left trace). That is, the rate used to toggle the field driving the modulator is slower than the liquid crystal’s free relaxation response. The ripple represents a phase error when the modulator is used in its phase-only mode (input polarization aligned with modulator’s optic axis). To eliminate the ripple, the toggle rate needs to be several times faster than the modulator’s response (right trace). This requires active matrix backplanes and drive electronics capable of sub-millisecond load rates such as the BNS XY Nematic Series SLMs. For additional information on this topic please refer to our [High Speed Addressing White Paper](#).

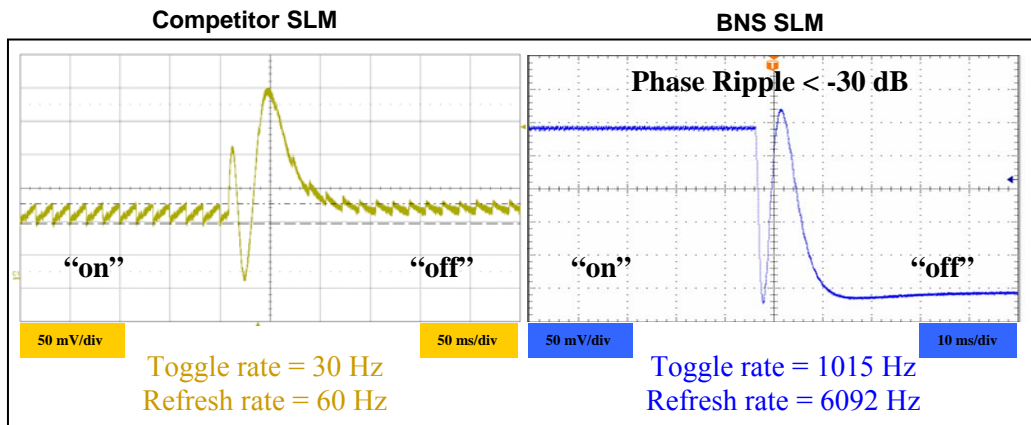

Two parallel-aligned nematic LC modulators addressed at different rates. The left trace shows a strong data-dependent ripple that is synchronous with the video-rate addressing period. The right trace shows complete suppression of the ripple with sub-millisecond addressing – the standard for all BNS SLMs.

100% Fill Factor

All of the light reflecting off of the spatial light modulator is modulated – including the light between the aluminum pixel electrodes. The reflective pixel structure associated with an LCoS SLM backplane acts as an amplitude grating that diffracts some light into higher orders. To eliminate this loss of light BNS has developed a process for remove the grating effects due to the pixel structure. Optically, the active area of the backplane is converted into a flat dielectric mirror by depositing planar dielectric layers to eliminate the amplitude and optical path variations associated with the underlying aluminum pixel structure. The dielectric stack is kept thin to minimize any drop in electric field across the LC layer as shown in the figure to the right. In other words, there are no abrupt changes in phase modulation (such as dead zones) between pixels due to the smoothing (low pass spatial filtering) which results from separating the LC modulator from the driving electrodes. Please refer to our [100% Fill Factor White Paper](#) for additional information on this topic.

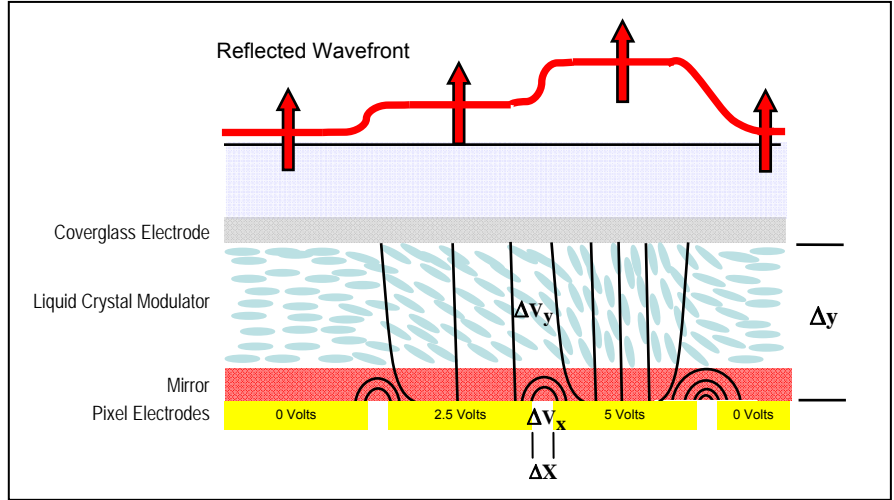

Planar High Efficiency mirror and smoothing of the electric field eliminate most of the grating effects associated with pixellated spatial light modulators.

High Optical Resolution

The optical resolution of a modulo- 2π (one-wave) phase modulator is related to its ability to produce phase wraps (i.e. a transition of 2π radians) over a small distance - preferably within a pixel pair. That is, the full resolution capability of the SLM is realized by producing phase wraps within the line-pair resolution of the LCoS backplane. Ideally this transition width is zero, but in reality will always have some width that is directly related to the thickness of the various layers in the modulator and the voltage potential between adjacent pixel electrodes, and between the coverglass electrode. This smoothing eliminates inter-pixel dead zones, but it increases pixel-to-pixel influence. Therefore, the distance from pixel pad to coverglass electrode needs to be small in relation to the LCoS pixel pitch to maximize spatial resolution (note: pixel pitch is center-to-center spacing of the pixel pads and is not the electrode gap distance shown in the figure above. These transitions (vertical lines) are approximately two pixels wide for both devices as shown. We verified this further by using higher magnification and higher frequency patterns. Please refer to our [High Optical Resolution White Paper](#) for additional information.

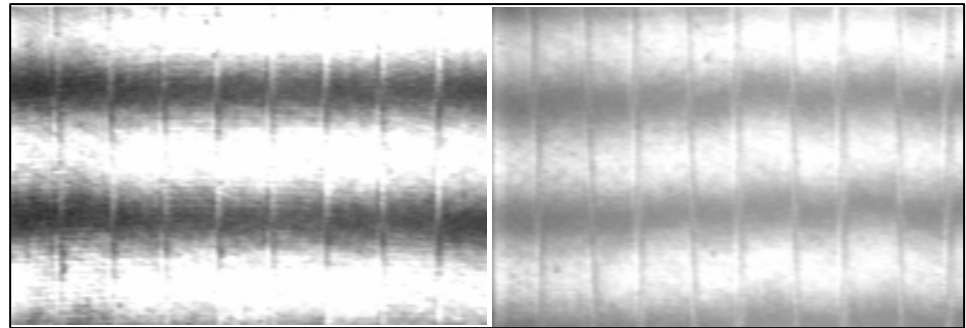

Interferometer images of two 512 x 512 XY Phase Series SLMs operating at 1064 nm. The left image has no dielectric mirror, the right image has a dielectric mirror. The pattern written to each SLM has 15 pixels set to zero phase and 16 pixels set to one wave of phase stroke. The discontinuities in the horizontal interference fringes show the relative width of the one-wave phase transition.

LCoS SLM Hardware Interface Options

Introduction

BNS offers three hardware interface options for our LCoS SLMs: PCI, PCI Express (PCIe), or DVI offering added flexibility to meet the most demanding customer applications.

Modes of Operation

BNS expects the user to operate in one of two different possible modes of operation: preload or continuous download. In preload mode the user has a predefined set of patterns to load on the SLM and the user would like to sequence through these patterns at a user defined frame rate. In continuous download mode the user is dynamically generating images, and loading them to the SLM in some form of a closed loop system. The specifications are different for the two modes, and will be discussed individually in the sections to follow.

DVI

For applications that are not concerned with latency or exact timing, but that desire a standard video interface to the SLM this is an appropriate hardware choice.

The DVI interface only supports continuous download mode, there is no on board memory to support preload mode. This controller provides 16-bit pixel data to the SLM. Calibrations of the nonlinear optical response of the liquid crystal to voltage can be loaded to the hardware, thus reducing system latency, and minimizing the need for the customer to understand the procedure to apply the calibration.

In the continuous download mode, 16-bit 512x512 images can be transferred across the DVI interface at a rate limited by the graphics card used. If a custom graphics card is used the hardware supports up to 1 kHz frame rates. However, standard graphics cards are typically limited to 60 - 75 Hz refresh rates. The actual achieved frame rate is variable, with dependence on the computer and the software interface used. The achieved frame rate steps in increments of the monitor refresh, i.e. for a 75 Hz refresh and a C++ interface the image will sometimes update in 13.3 ms, but could update in 26.6 ms. In some system configurations the DVI interface may be slower than the liquid crystal response time.

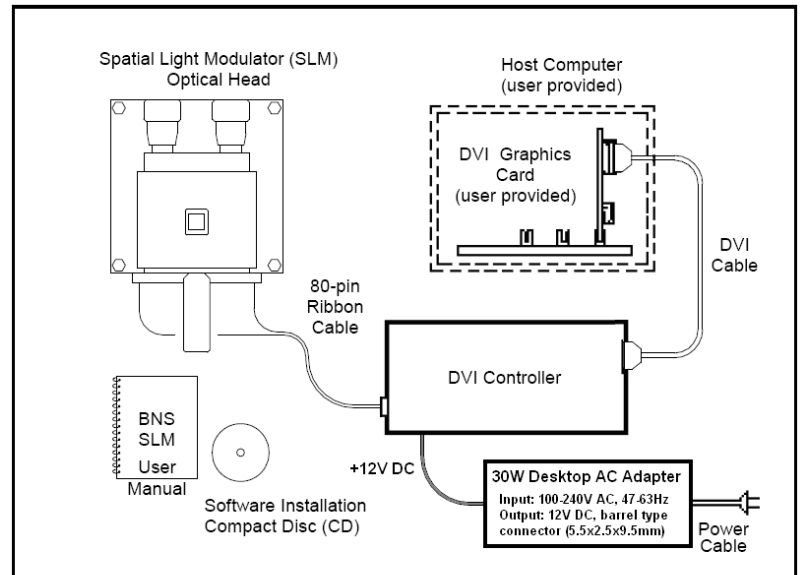

DVI Driver Hardware for LCoS SLM

The standard product software reads in the contents of a folder, and allows the user to either manually select an image to display on the SLM, or to load the images to the SLM sequentially using software timers. The software timers used to update the SLM are not highly accurate, so it is not possible to transfer images on a precise interval. However, if synchronizing into a larger system, triggers can be used to determine when a new image is on the SLM. The standard software uses a dualview mode, allowing the user to maintain full control over the primary monitor while actively driving the SLM.

In order to support 16-bit operation, 24-bit images are used, where 8-bits are blue, 8-bits are green, and 8-bits are red. The blue bits are ignored by the hardware, the green bits are the 8 most significant bits, and the red bits are the 8 least significant bits. If 8-bit images are loaded to the SLM through the BNS software interface, the 8-bits are assigned to the 8 most significant bits. These images will appear green in the user interface.

Images are transferred through the graphics card, meaning that the graphics card settings are critical to the operation of the SLM. Specifically, using the nVidia NVS 290 256MB dual DVI Graphics card, gamma must be set to 50% to get the expected mapping of input values to output values after passing through the graphics card, and for the BNS supplied LUT calibration to function properly. BNS cannot guarantee identical operation for all graphics cards. If a different graphics card is used it is recommended that the SLM calibrations be verified prior to use.

PCI

Applications that require multiple SLMs to be driven synchronously to within a single clock can only use the PCI interface. Such applications include but are not limited to optical correlators.

The PCI interface supports both the preload mode and the continuous download mode. This controller provides 8-bit pixel data to the SLM. Calibrations of the nonlinear optical response of the liquid crystal to voltage must be done in software, adding some latency to the image transfer.

In the preload mode 8-bit 512x512 images can be transferred across the PCI bus in approximately 5.6 ms (exact time is computer dependent). There is a bank of memory in the PCI board capable of storing to 1024 512x512 8-bit images. Stored images can be accessed in any random order. Images that are stored in the hardware memory can be transferred from the PCI board to the SLM in 1 ms. The user can define frame rates ranging from 1 Hz to 1 kHz (in many instances the liquid crystal response time will limit the frame rate to slower rates). The image transfer timing from the PCI memory to the SLM is controlled though hardware generated interrupts, offering timing with a high degree of precision..

In the continuous download mode, images pass through the PCI board memory, but are immediately transferred to the SLM. In this case the data transfer time is approximately 6.6.

The standard Blink Compact software is meant to operate in a preload mode. However, the optional Matlab, C++, and LabVIEW software development kits outline an order of operation for running in a continuous download mode.

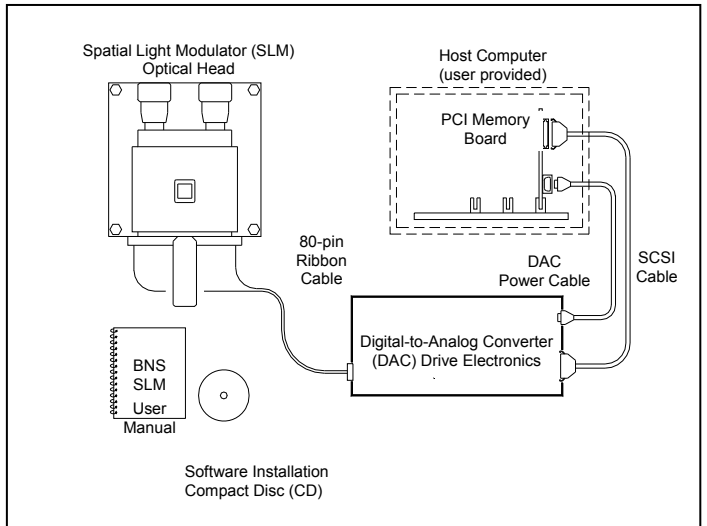

PCIe

For applications that require minimal latency such as atmospheric turbulence simulation/correction or real-time optical trapping systems the PCIe interface is an appropriate choice.

The PCIe interface only supports continuous download mode, there is no on board memory to support preload mode. This controller provides 8-bit pixel data to the SLM. Calibrations of the nonlinear optical response of the liquid crystal to voltage can be loaded to the hardware, thus reducing system latency, and minimizing the need for the customer to understand the procedure to apply the calibration.

In the continuous download mode 8-bit 512x512 images can be transferred across the PCIe bus in approximately 600 us using an x4, or larger, PCIe slot.

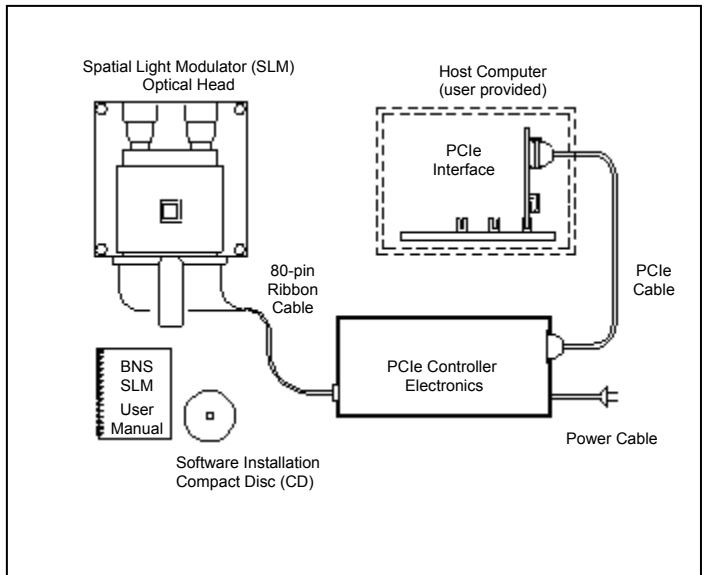

The standard product software reads in the contents of a folder, and allows the user to either manually select an image to display on the SLM, or to load the images to the SLM sequentially using software timers. Software timers are not highly accurate, so it is not possible to transfer images on a precise interval. However, if synchronizing into a larger system, triggers can be used to determine when a new image is on the SLM.

Host Computer Requirements

In order to effectively utilize your BNS SLM, basic computing hardware is required. The following components are essential to properly achieve the full performance of your SLM system.

1. **Operating system** (Windows 2000 or XP Professional). Mouse or other pointing device. Display monitor with 800 x 600 pixel format (minimum) and 256 colors (or more).
2. **32 megabytes (MB)** of available hard disk space required for BLINK basic software installation.
3. **32 MB** of available random access memory (RAM) to store and manage user-selected frames.
4. **Depending on the type of controller selected:**
 - a. PCI – one open full length PCI slot
 - b. PCIe – one open x4, or larger PCIe slot
 - c. DVI – Graphics controller with available DVI-D connector.

SLM Construction

Several parameters help define SLM characteristics. Pixel pitch is defined as the center-to-center spacing between adjacent pixels. Interpixel gap describes the edge-to-edge spacing between adjacent pixels. Figure 4 below illustrates basic specifications used to describe our reflective SLM products.

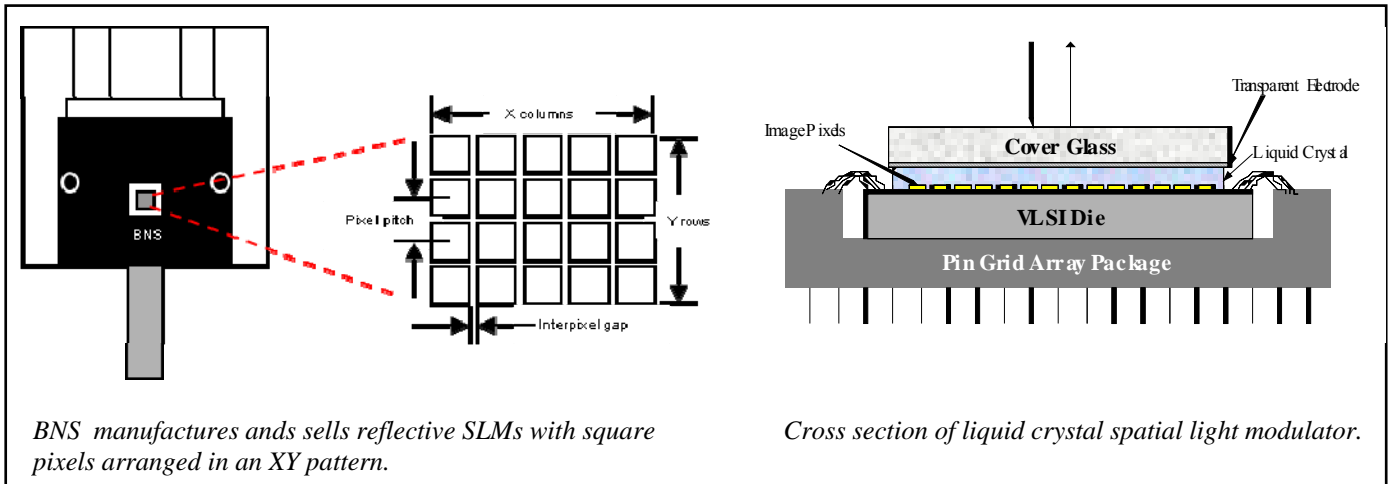

Polarized light enters the device from the top, passes through the cover glass, transparent electrode and liquid crystal layer, is reflected off the shiny pixel electrodes, and returns on the same path. Drive signals travel through the pins on the bottom of the pin-grid array package, through the bond wires and into the silicon die circuitry. The voltage induced on each electrode (pixel) produces an electric field between that electrode and the transparent electrode on the cover glass. This field produces a change in the optical properties of the LC layer. Because each pixel is independently controlled, a phase pattern may be generated by loading different voltages onto each pixel.

Software Options

Boulder Nonlinear Systems (BNS) offers several software options, enabling the user to select a program that will best suit their needs. These versions of software have different levels of functionality:

- *Blink Compact (Included)*
- *Blink Plus (Included only with PhaseFlat)*
- *Blink Full (Optional)*
- *Visual C++ Software Developer Kit (Optional)*
- *LabView Software Developer Kit (Optional)*
- *MatLab Software Developer Kit (Optional)*

(see *Software Data sheet for complete descriptions*)

Blink Compact

Blink Compact is the basic software included with each purchase of a XY Nematic or FLC SLM system. Each CD contains custom configuration files designed to provide improved performance on startup.

Blink Plus

Blink Plus includes all of the features of Blink Compact, plus an added feature to remove the static phase patterns when working with the XY Nematic Series SLMs. (Not compatible with XY Ferroelectric Series SLMs.) Blink Plus is included with the purchase of a XY PhaseFlat SLM system. Each CD contains custom configuration files designed to provide improved performance on startup.

Blink Full

Intended for programmer's familiar with Microsoft Visual C++ and device driver design, Blink Full is useful for those who wish to write their own software interface, and wish to modify the device driver. This software package includes the source code used to generate the Blink program. Source code is included for the upper level graphical user interface, as well as for the run-time libraries and device drivers.

Visual C++ Software Developer Kit

Intended for programmers familiar with Microsoft Visual C++ who intend to write their own software interface, but have little desire to understand or to modify the device driver. This simplified software package has a minimal user interface. It is meant to demonstrate how to call the run time library functions available to the user, and the order that those functions should be called in. An included example shows the user how to perform basic functions. Source code is included for the upper level graphical user interface, but is not included for the device driver.

LabVIEW Software Developers Kit

Intended for programmer's familiar with Microsoft Visual C++ and LabVIEW who intend to write his or her own LabVIEW VI to drive the SLM, but have little desire to understand or to modify the device driver. This simplified software package has a minimal user interface. It is meant to demonstrate how to call C++ functions through a DLL from LabVIEW, and the order that those functions should be called in.

Matlab Software Developer Kit

Intended for programmers familiar with Matlab who intend to write their own software interface, but have little desire to understand or to modify the device driver. This simplified software package has a minimal user interface. It is meant to demonstrate how to call the run time library functions available to the user, and the order that those functions should be called in.

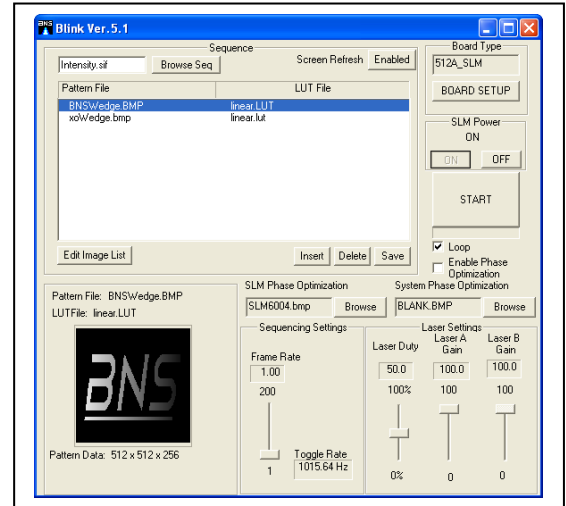

512 NEMATIC SLM SPECIFICATIONS

	Model P512 – 0532	Model P512 – 0635	Model P512 – 0785	Model P512 – 1064	Model P512 – 1550
Array Size	7.68 x 7.68 mm				
Zero-Order Diffraction Efficiency (standard)	61.5% (maximum)				
Zero-Order Diffraction Efficiency (with High Efficiency Mirror)	90 - 95% (maximum)				
Duty Cycle	Up to 100%				
External Window - 600 to 1300 nm also available (see chart on page 12)	Broadband antireflection coated for $R_{avg} < 1\%$ (over 450 - 865 nm)			Broadband antireflection coated for $R_{avg} < 1\%$ (over 850 - 1650 nm)	
Fill Factor (standard product)	83.4%				
Fill Factor (with High Efficiency Mirror)	100%				
Format	512 x 512 (262,144 active pixels)				
Mode	Reflective				
Modulation	Controllable index of refraction				
Phase Levels (resolvable)	50 linear levels (minimum) for 2π phase stroke with PCI or PCIe 8-bit Controller			100 linear levels (minimum) for 2π phase stroke with PCI or PCIe 8-bit Controller	
	1,000 – 8,000 linear levels (minimum) with DVI 16-bit Controller			2,000 – 16,000 linear levels (minimum) for 2π phase stroke with DVI 16-bit Controller	
Phase Stroke (double-pass)	Typically 2π (π to 12π upon request)				
Contrast Ratio (if used in Amplitude Mode)	200:1				
Pixel Pitch	15 x 15 μ m				
Spatial Resolution	33 lp/mm				
Reflected Wavefront Distortion - RMS (standard)	$\lambda/3$ @ 532 nm	$\lambda/4$ @ 635 nm	$\lambda/5$ @ 785 nm	$\lambda/6$ @ 1064 nm	$\lambda/8$ @ 1550 nm
Reflected Wavefront Distortion – RMS (PhaseFlat)	$\lambda/12$ @ 532 nm	$\lambda/15$ @ 635 nm	$\lambda/20$ @ 785 nm	$\lambda/20$ @ 1064 nm	$\lambda/20$ @ 1550 nm
Standard Liquid Crystal Response Time / Switching Frequency	≤ 33.3 ms / ≥ 30 Hz	≤ 33.3 ms / ≥ 30 Hz	≤ 55.5 ms / ≥ 18 Hz	≤ 66.7 ms / ≥ 15 Hz	≤ 100 ms / ≥ 10 Hz
High Speed Liquid Crystal Response Time / Switching Frequency	≤ 7 ms / ≥ 142 Hz	≤ 12 ms / ≥ 83 Hz	≤ 17.2 ms / ≥ 58 Hz	≤ 10 ms / ≥ 100 Hz	≤ 20 ms / ≥ 50 Hz
High Efficiency with High Speed Liquid Crystal Response Time / Switching Frequency	≤ 10 ms / ≥ 100 Hz	≤ 16.7 ms / ≥ 60 Hz	≤ 22.2 ms / ≥ 45 Hz	≤ 16.7 ms / ≥ 60 Hz	≤ 28.5 ms / ≥ 35 Hz
Wavelength Range	515 – 585 nm	615 – 700 nm	760 - 865 nm	1030 - 1170 nm	1505 - 1650 nm

256 NEMATIC SLM SPECIFICATIONS

	Model HSP256 – 0532	Model HSP256 – 0635	Model HSP256 – 0785	Model HSP256 – 1064	Model HSP256 – 1550
Array Size	6.14 x 6.14 mm				
Zero-order Diffraction Efficiency (standard)	71.5% (maximum)				
Zero-Order Diffraction Efficiency (with High Efficiency Mirror)	90 - 95% (maximum)				
Duty Cycle	Up to 100%				
External Window - 600 to 1300 nm also available (see chart on page 12)	Broadband antireflection coated for $R_{avg} < 1\%$ (over 450 - 865 nm)			Broadband antireflection coated for $R_{avg} < 1\%$ (over 850 - 1650 nm)	
Fill Factor (standard product)	90%				
Fill Factor (with High Efficiency Mirror)	100%				
Format	256 x 256 (65,536 active pixels)				
Mode	Reflective				
Modulation	Controllable index of refraction				
Phase Levels (resolvable)	50 linear levels (minimum) for 2π phase stroke with PCI or PCIe 8-bit Controller			100 linear levels (minimum) for 2π phase stroke with PCI or PCIe 8-bit Controller	
	1,000 – 8,000 linear levels (minimum) with DVI 16-bit Controller			2,000 – 16,000 linear levels (minimum) for 2π phase stroke with DVI 16-bit Controller	
Phase Stroke (double-pass)	Typically 2π at user-specified laser line				
Contrast Ratio (if used in Amplitude Mode)	200:1				
Pixel Pitch	24 x 24 μm				
Spatial Resolution	20 lp/mm				
Reflected Wavefront Distortion - RMS (standard)	$\lambda/7$ @ 532 nm	$\lambda/8$ @ 635 nm	$\lambda/10$ @ 785 nm	$\lambda/12$ @ 1064 nm	$\lambda/15$ @ 1550 nm
High Speed Liquid Crystal Response Time / Switching Frequency	≤ 2 ms / ≥ 500 Hz	≤ 2.5 ms / ≥ 400 Hz	≤ 4.5 ms / ≥ 222 Hz	≤ 7 ms / ≥ 142 Hz	≤ 14 ms / ≥ 71 Hz
High Efficiency with High Speed Liquid Crystal Response Time / Switching Frequency	≤ 2.8 ms / ≥ 350 Hz	≤ 3.3 ms / ≥ 300 Hz	≤ 5.7 ms / ≥ 175 Hz	≤ 10 ms / ≥ 100 Hz	≤ 20 ms / ≥ 50 Hz
Wavelength Range	515 – 585 nm	615 – 700 nm	760 - 865 nm	1030 - 1170 nm	1505 - 1650 nm

PhaseFlat and Standard Liquid Crystal are not available with 256x256 Model.

FLC SLM SPECIFICATIONS

	Model A512 – 0532	Model A512 – 0635	Model A512 – 0785	Model A512 – 1064	Model A512 – 1550
Array Size	7.68 x 7.68 mm				
Format	512 x 512 (262,144 active pixels)				
Zero-Order Diffraction Efficiency (standard)	61.5% (maximum)				
External Window	Broadband antireflection coated for $R_{avg} < 1\%$ (over 450 - 865 nm)			Broadband antireflection coated for $R_{avg} < 1\%$ (over 850 - 1650 nm)	
Mode	Reflective				
Modulation	Controllable optic axis orientation				
Contrast Ratio (monochromatic input light)	200:1				
FLC Response Time	$\leq 450 \mu s$				
FLC Switching Frequency	1015 Hz (maximum)				
Duty Cycle	50%				

FLC SLMs are available in 512 x 512 models only.

DRIVER SPECIFICATIONS

	PCI	PCI-e	DVI
Transfer Time (computer dependent)	5.6 ms (CPU to memory) 1.0 ms (memory to SLM)	600 μs (CPU to SLM)	60 Hz – 16.7 ms (CPU to SLM) 200 Hz – 5.0 ms (CPU to SLM)
Driver Phase Levels	256 (8-bits)	256 (8-bits)	65,536 (16-bits) Combined red & green channels
Linear Phase Levels	50 – 100 linear minimum	50 – 100 linear minimum	1,000 linear minimum
Platform Independence Window / Driver	NO	NO	Windows Color Pallet Dependent
On Board Look-Up-Table (LUT)	No	Yes	Yes
On Board Memory Bank	Yes	No	No
SLM Models Available	256x256, 512x512, 1x12,288 (all models)	High Speed 512x512, 256x256	60 Hz – Standard 512x512 200 Hz – High Speed 512x512

Spatial Light Modulator Cover Glass Options

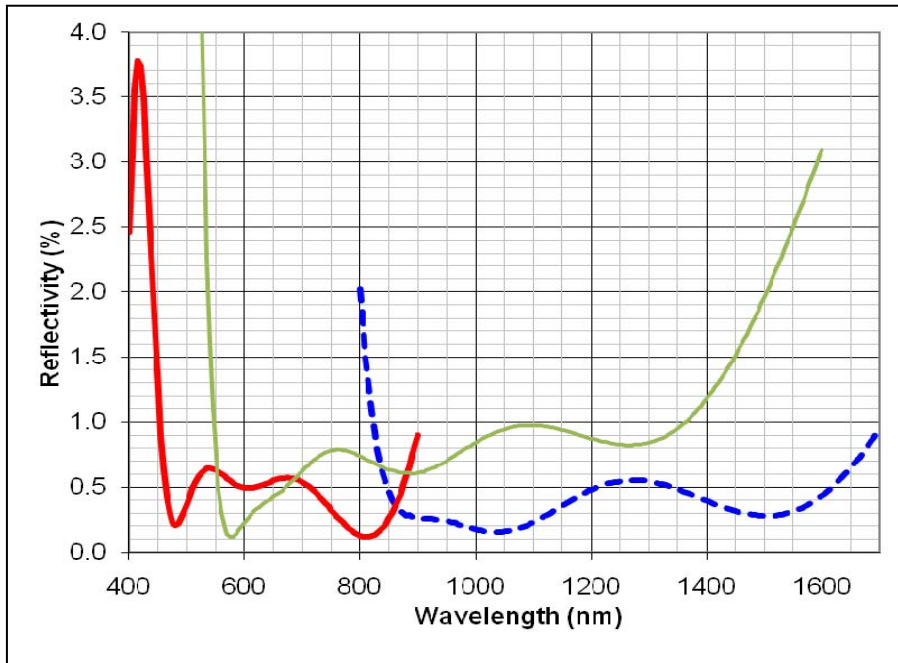

Cover Glass Reflectivity Performance (chart referenced on pages 9 and 10)

Company Profile

Boulder Nonlinear Systems, Inc. (BNS) is an innovative technology company specializing in dynamic liquid crystal polarization control solutions for both laser-based and imaging systems. Company strengths in scientific research and development are leveraged into OEM and standard product offerings targeted for astronomy, biomedical, defense, microscopy, optical computing, optical storage, and telecommunications applications.

For additional product and company information, please contact:

Boulder Nonlinear Systems, Inc.
450 Courtney Way
Lafayette, CO 80026 – 8878
USA

Telephone: (303) 604 – 0077
Toll free: (866) 466 – 0506
Fax: (303) 604 – 0066
E-mail: sales@bnonlinear.com
Website: www.bnonlinear.com

© July 2009 Boulder Nonlinear Systems, Inc.