

Spatial Light Modulators

Features

- High optical efficiency
- No mechanical motion
- High speed phase control
- Safe, low voltage operation
- User-friendly graphical interface

Applications

- Beam steering
- Diffractive Optics
- Ultra-fast pulse shaping
- Spectral tuning / processing
- Programmable phase gratings
- Programmable amplitude gratings

Benefits

- Full user programmability
- Flexible system configuration
- Quiet, low-vibration operation
- Solid state device construction
- Easy plug-and-play installation

Description

A Spatial Light Modulator (SLM) is a device that modulates light according to a fixed spatial (pixel) pattern. SLMs have an expanding role in several optical areas where light control on a pixel-by-pixel basis is critical for optimum system performance. SLMs are typically used to control incident light in amplitude-only, phase-only or the combination (phase-amplitude).

Boulder Nonlinear Systems (BNS) manufactures and sells liquid crystal based Spatial Light Modulators for a variety of applications. All BNS SLMs operate in reflection, based on liquid crystal on silicon (LCoS) technology.

Key features of our SLMs include high speed phase or amplitude modulation, high efficiency operation, and a complete, user-friendly graphical software interface.

Several parameters help define SLM characteristics. Pixel pitch is defined as the center-to-center spacing between adjacent pixels. Interpixel gap describes the edge-to-edge spacing between adjacent pixels. Figure 1 below illustrates basic specifications used to describe our reflective SLM products.

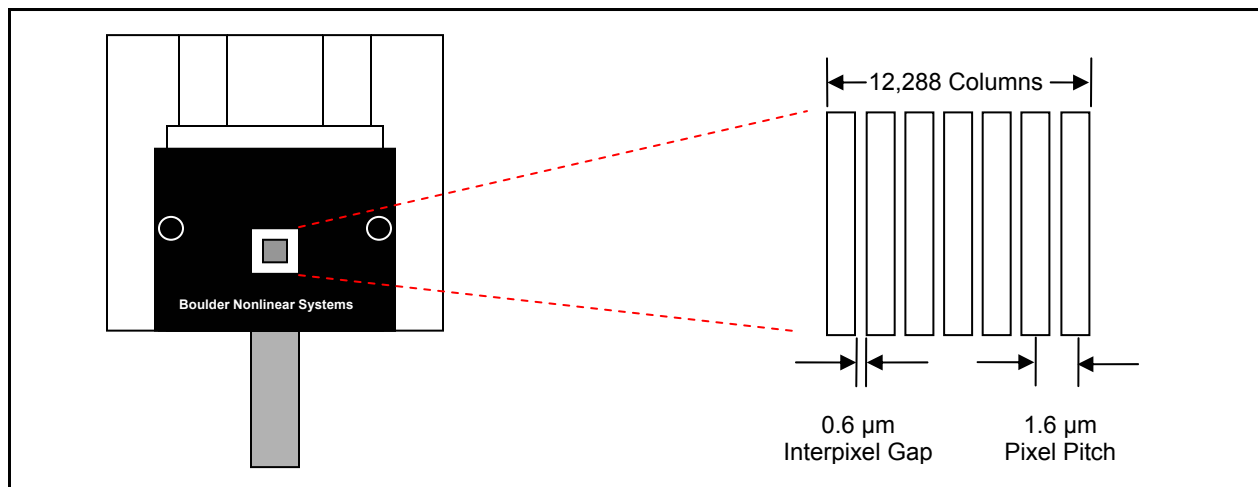

Figure 1 ~ Boulder Nonlinear Systems manufactures and sells reflective Linear Spatial Light Modulators (SLMs) with a very fine pitch for applications requiring high spatial resolution.



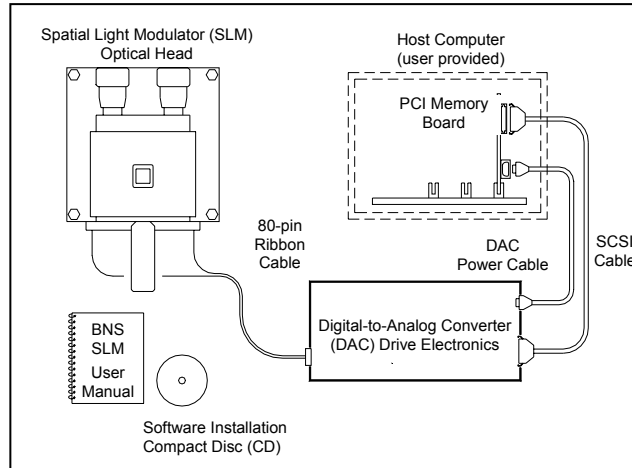

Figure 2 ~ Top level diagram illustrating major components of the BNS SLM system contents.

Linear Series SLMs

Boulder Nonlinear Systems, Inc. (BNS) Linear Series Spatial Light Modulators (SLMs) are designed for versatility and ease of use in typical optical laboratory environments. Our standard formats match specific simulation and modeling needs in non-mechanical beamsteering and other related application areas. BNS also customizes SLM systems for wavelength-specific requirements.

Spatial Light Modulator System Contents

Figure 2 above illustrates the major components included with the BNS SLM system. Each SLM System includes the following five elements:

1. **Spatial Light Modulator (SLM) Optical Head** with high sensitivity, two-axis, graduated control and adjustment ($\pm 3^\circ$ total travel). Post mount mates with most standard half-inch post holders.
2. **Digital-to-Analog Converter (DAC) Drive Electronics** and all necessary cabling (including 80-pin ribbon, DAC power, and SCSI cables).
3. **Personal Computer Interface (PCI)** full-length memory board, which conveniently mates with standard PCI slot.
4. **SLM User Manual** with complete instructions for set-up, installation, care, handling, and basic system troubleshooting of your SLM system.
5. **Software Installation Compact Disk (CD)** including application-specific, plug-and-play, proprietary BLINK software.

Host Computer Requirements

In order to effectively utilize your BNS SLM, basic computing hardware is required. The following components are essential to properly achieve the full performance of your SLM system.

1. **IBM-compatible personal computer (PC).** Pentium[®]-based (100 MHz) system with compact disk (CD) drive and full-length PCI slot available. Windows[®]-based computer operating system (Windows 2000 or XP Professional). Mouse or other pointing device. Display monitor with 800 x 600 pixel format (minimum) and 256 colors (or more).
2. **32 megabytes (MB)** of available hard disk space required for BLINK basic software installation.
3. **32 MB** of available random access memory (RAM) to store and manage user-selected frames.

All Boulder Nonlinear Systems, Inc. (BNS) Spatial Light Modulators (SLMs) include two-axis (tip-tilt) adjustment as standard.

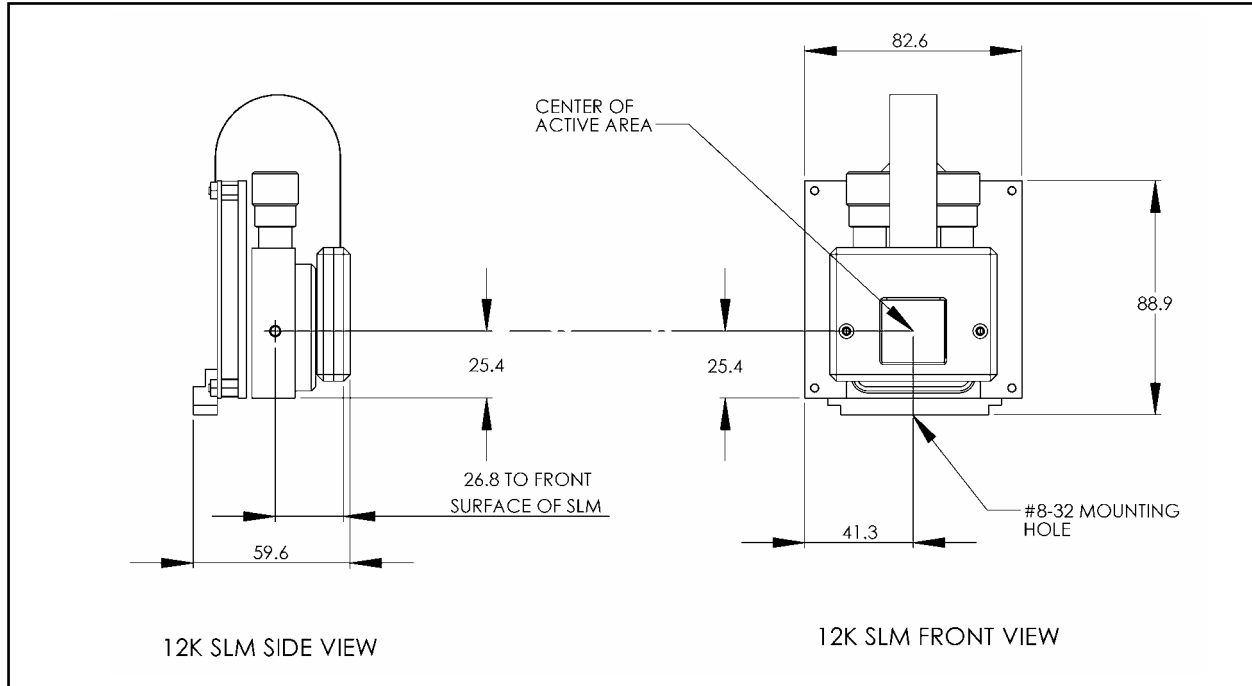

*Figure 3 ~ Outline drawing showing front and side views of 1x12,288 Optical Head.
Dimensions in millimeters.*

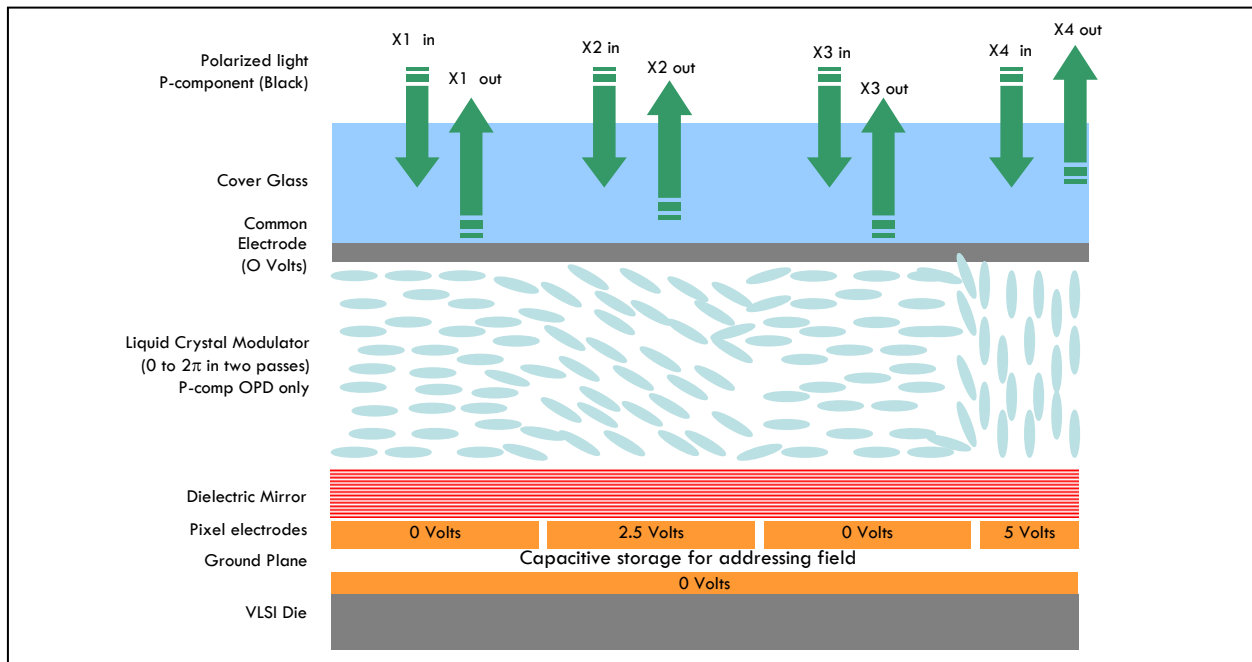

Figure 4 ~ Cross Section of Optically-efficient Phase Only LCoS SLM

Spatial Light Modulators

Linear Series

Specifications (Draft)

	Model P12,288 – λ (nm) – PT
Array Size	19.66 x 19.66 mm
Design Wavelength (nominal)	635 – 1550 nm (specify wavelength, λ in nm when ordering)
Diffraction Efficiency (zero-order)	80 - 95% (maximum)
Duty Cycle	Up to 100%
External Window¹	Broadband antireflection coated for $R_{avg} < 1\%$ (over 450 – 865 nm or 850 – 1650 nm).
Fill Factor	100%
Format	1 x 12,288 (12,288 active pixels)
Mode	Reflective
Steering Angle	$\pm 4 - 7^\circ$
Modulation	Controllable index of refraction
Phase Levels (resolvable)	50 - 100 linear levels (minimum) for 2π phase stroke
Phase Stroke (double-pass)	Typically 2π at user-specified laser line
Pixel Pitch	1.6 μm
Reflected Wavefront Distortion (rms)²	$\lambda/10 - \lambda$
Response Time³	5 - 30 ms
Spatial Resolution	TBD
Switching Frequency³	30 - 200 Hz

1. Custom antireflection coating options are also available, including V-type for optimum optical efficiency at a single laser wavelength.
2. At nominal wavelength.
3. Phase stroke, temperature, and wavelength dependent.

Above specifications are subject to change without notice. Please contact Boulder Nonlinear Systems for additional updates.

Company Profile

Boulder Nonlinear Systems, Inc. (BNS) is an innovative technology company specializing in dynamic liquid crystal polarization control solutions for both laser-based and imaging systems. Company strengths in scientific research and development are leveraged into OEM and standard product offerings targeted for astronomy, biomedical, defense, microscopy, optical computing, optical storage, and telecommunications applications.

For additional product and company information, please contact:

Boulder Nonlinear Systems, Inc.
450 Courtney Way
Lafayette, CO 80026 – 8878
USA

Telephone: (303) 604 – 0077
Toll free: (866) 466 – 0506
Fax: (303) 604 – 0066
E-mail: sales@bnonlinear.com
Website: www.bnonlinear.com